

Electrohydraulic Synchronizing Servo Control of a Robotic Arm

This article has been downloaded from IOPscience. Please scroll down to see the full text article.

2006 J. Phys.: Conf. Ser. 48 1268

(<http://iopscience.iop.org/1742-6596/48/1/236>)

View [the table of contents for this issue](#), or go to the [journal homepage](#) for more

Download details:

IP Address: 38.107.179.212

The article was downloaded on 15/02/2012 at 00:14

Please note that [terms and conditions apply](#).

Electrohydraulic Synchronizing Servo Control of a Robotic Arm

S Li, J Ruan, X Pei, Z Q Yu and F M Zhu

The MOE Key Laboratory of Mechanical Manufacture and Automation
Zhejiang University of Technology China, 310014

E-mail: li_sheng@mail.hz.zj.cn

Abstract. The large robotic arm is usually driven by the electrohydraulic synchronizing control system. The electrohydraulic synchronizing system is designed with the digital valve to eliminate the effect of the nonlinearities, such as hysteresis, saturation, definite resolution. The working principle of the electrohydraulic synchronizing control system is introduced and the mathematical model is established through construction of flow rate equation, continuity equation, force equilibrium equation, etc. To obtain the high accuracy, the PID control is introduced in the system. Simulation analysis shows that the dynamic performance of the synchronizing system is good, and its steady state error is very small. To validate the results, the experimental set-up of the synchronizing system is built. The experiment makes it clear that the control system has high accuracy. The synchronizing system can be applied widely in practice.

1. Introduction

Due to the consideration of force equilibrium and the structural limitations, the large robotic arm has to be driven synchronously by two hydraulic cylinders. The synchronizing accuracy of the hydraulic cylinders affects not only the positioning accuracy of the whole arm but also the smoothness of the arm's motion. At present, there are many kinds of the electrohydraulic synchronizing control system. Some electrohydraulic synchronizing control systems run in open loop, for instance, mechanical stiffness synchronizing control system, flow divider and combiner synchronizing control system, etc. The structures of these open loop control system are simple, but their synchronizing accuracy is lower. Thus, when high synchronizing accuracy is needed, the closed-loop control system is usually applied. Some closed-loop systems are designed with a servo valve. Though these systems can run with high synchronizing accuracy, they tend to be weak in the capability of preventing oil from contamination. And some closed-loop systems are designed with the proportional valve. Those systems are much better in contamination-proof, but are not good enough in both static and dynamic performance for the application in the servo control because of hysteresis, saturation, definite resolution nonlinearities. To obtain high synchronizing accuracy, an electrohydraulic synchronizing control system is designed with a digital valve.

2. Electrohydraulic synchronizing control system

Figure 1 is the scheme of electrohydraulic synchronizing servo control system. In the synchronizing system, when the active cylinder 3 is actuated through the directional valve 6 and its piston will move, the motion will be detected by the displacement sensor 1 attached on the piston of the active cylinder. This signal is compared with that from displacement sensor 2 attached on the piston of the passive

cylinder. The resulted difference between these two signals is fed to control the electrohydraulic valve 5 to keep the passive cylinder synchronized with the active one.

In the synchronizing system, the kernel control component is digital valve 5, shown in figure 2. The valve is a 2-dimension valve. Both rotary and linear motions of the spool characterize the valve. The spool will have a linear motion while the stepper motor rotates within a certain angle and the spool could be precisely positioned by controlling the angular displacement of the stepper motor. The stepper motor is an electrical-to-mechanical transformer used in the valve the used and is controlled by a specially developed program, called “tracking algorithm”. In this way, the stepper motor can output continual angular displacement and thus both the dynamic response and the accuracy of the valve are simultaneously sustained.

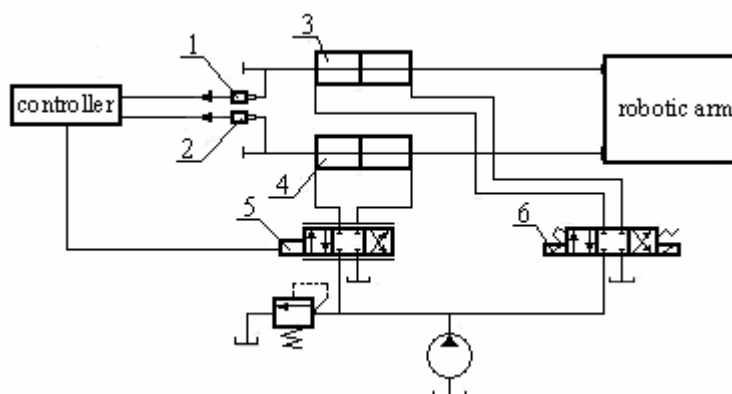

Figure 1. Scheme of electrohydraulic synchronizing control.

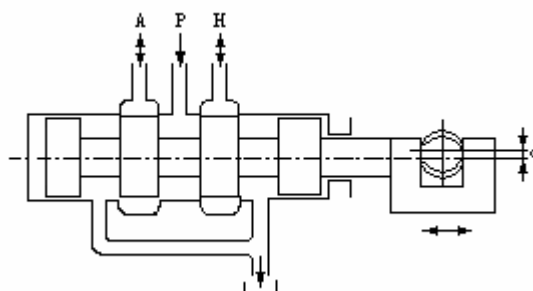

Figure 2. Digital Valve.

The valve plays a key role in an electrohydraulic servo control system and dominates to a large extent the performance of the whole control system. For this reason an electrohydraulic digital valve is applied in the electrohydraulic synchronizing servo control system to meet the requirement of high synchronizing control accuracy. Compared with other electrohydraulic synchronizing servo control system composed of the electrohydraulic servo valves or proportional valves, the synchronizing control system avoids the affects of the nonlinearity of saturation and hysteresis. Therefore, it can meet the requirement of high synchronizing control accuracy.

3. Mathematical model of the system

According to the working principle of the synchronizing control system, the motion of the passive cylinder can be described through construction of flow rate equation, continuity equation and force equilibrium equation.

3.1. Flow rate equation

The cylinder controlled by the valve can be described by the flow rate equation as follow:

$$Q_L = K_q x_V - K_C P_L \quad (1)$$

where K_q is the flow rate gain; K_c is the flow-pressure coefficient; x_v is the displacement; p_L is the load pressure; Q_L is the load flow rate.

3.2. Continuity equation

To establish the continuity equation of the cylinder, the following assumptions are set:

- All pipe in the system is short and wide. So the pipe loss and oil mass can be negligible.
- The leakage of the cylinder flows in a laminar state.
- The system pressure p_s is constant.
- To simple analysis, the piston is in the middle of the cylinder.

The continuity equation of the cylinder is

$$Q_L = A_p \frac{dx_p}{dt} + 2K_{lc} p_L + \frac{V_t}{4E_h} \frac{dp_L}{dt} \quad (2)$$

where K_{lc} is total leakage coefficient of the cylinder; E_h is the volumic modular coefficient of oil; A_p is the area of piston; x_p is the displacement of piston; V_t is the total volume of the cylinder.

3.3. Force equilibrium equation

When coulomb frictional force and mass of oil is negligible, the force equilibrium equation of the cylinder is

$$A_p (p_1 - p_2) = A_p p_L = m \frac{d^2 x_p}{dt^2} + B_p \frac{dx_p}{dt} + K x_p + F_L \quad (3)$$

where m is mass of the piston and load; B_p is coefficient of viscous frictional force; K stiffness of the spring of the load; F_L is the load.

Eq.1, Eq.2 and Eq.3 are there basic equations of the cylinder controlled by the valve. They decide its dynamic performance.

Usually, there is no elasticity load in the system, so K is zero. And considered $(A_p)^2/K_{ce} \gg B_p, B_p K_{ce}$ can be negligible. Therefore, in the case of $F_L=0$, applying the Laplace Transformation to Eq.1, Eq.2 and Eq.3, the following equation can be obtained

$$X_p = \frac{\frac{K_q}{A_p} X_v}{s \left(\frac{s^2}{\omega_h^2} + \frac{2\xi_h}{\omega_h} s + 1 \right)} \quad (4)$$

$$\text{where } \omega_h = \sqrt{\frac{4E_h A_p^2}{V_t m}} = \sqrt{\frac{K_h}{m}}; \quad K_h = \frac{4E_h A_p^2}{V_t}; \quad \xi_h = \frac{K_{ce}}{A_p} \sqrt{\frac{E_h m}{V_t}} + \frac{B_p}{4A_p} \sqrt{\frac{V_t}{E_h m}}.$$

4. Control strategy

To obtain high synchronizing control accuracy, control strategy is applied. The select of the control strategy is a very important work. PID is one of the appropriate control strategy. PID control is reliable and grown technique, which is applied widely into practice. PID arithmetic is expressed as

$$\frac{U(s)}{E(s)} = K_p \left(1 + \frac{1}{T_i s} + T_d s \right) \quad (5)$$

where K_p, T_i, T_d are respectively proportion coefficient, integral coefficient, derivative coefficient.

Control synchronizing accuracy lies on K_p, T_i and T_d . As a rule, the increase of proportion coefficient K_p will decrease the steady state error, and expedite the dynamic response. On the other hand, it will increase percent overshoot (PO) of the system. Integral action can eliminate the steady state error to raise synchronizing accuracy, but the increase of T_i will decrease stability. Derivative

action will improve the dynamic performance of the system. Therefore K_p , T_i and T_d must be reasonably chosen to obtain high synchronizing control accuracy.

5. Simulation and experiment

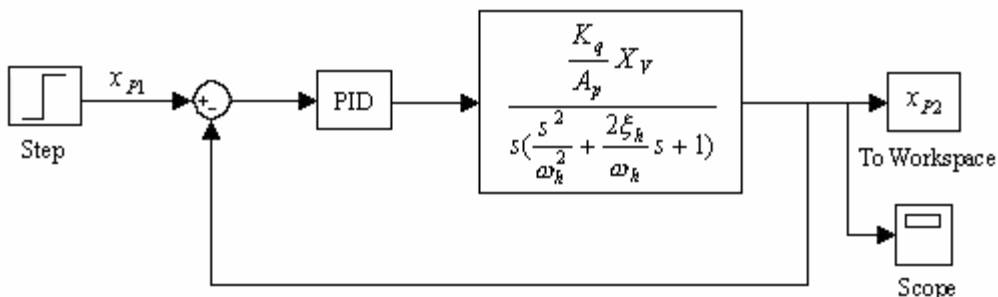

Figure 3. Block diagram of the system.

From Eq.4 and Eq.5, the simulation scheme of the control system is obtained, shown in Figure 3. According to the Figure 3, while the step signal is applying the control system, the simulation pattern is obtained, shown in Figure 4. From Figure 4, it can be clearly seen that the synchronizing control system has high control accuracy and the percent overshoot (PO) is very lower (about 8%). The result shows the model of the system is correct.

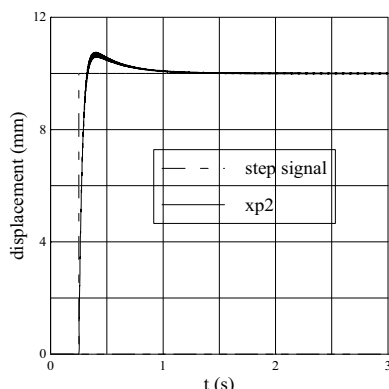

Figure 4. Simulation pattern.

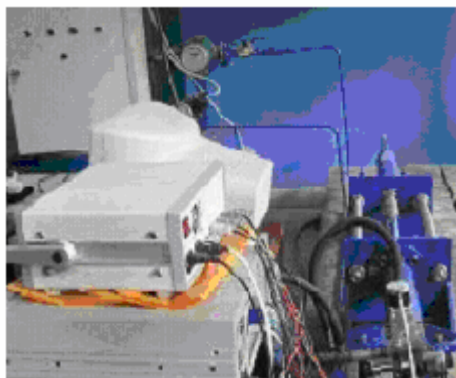

Figure 5. Experimental set-up.

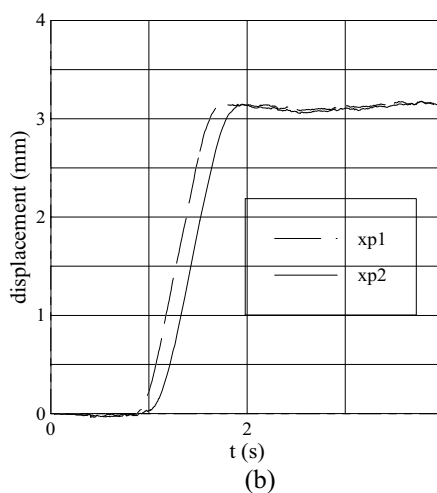
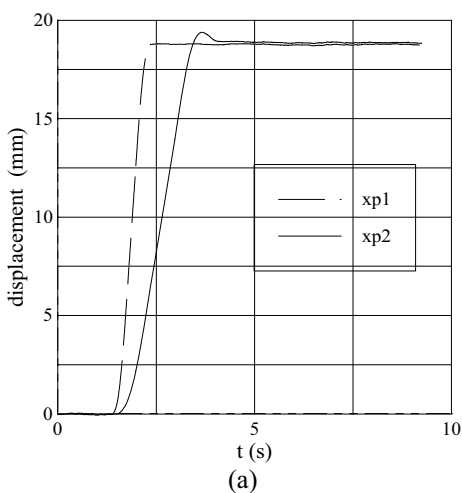

Figure 6. Measured pattern.

To validate the result, the actual test is carried out by the experimental set-up of the electrohydraulic synchronizing servo control, shown in Figure 5. The measured patterns are shown in

Figure 6. Figure 6 (a) is obtained while the step signal is applied the system, which is produced by shifting the displacement sensor 1 quickly. Figure 6 (b) is the motion pattern of the passive cylinder while the active cylinder moves. Comparing the Figure 6 (a) with the Figure 4, we can see that the actual step response is correspond to simulation results. And from the Figure 6, it is very obvious that the control system has high control accuracy.

6. Conclusion

Because the digital valve has the strong capability of preventing oil from contamination, high reliability, and do not has the nonlinearities demonstrated by the servo or proportional valves, such as hysteresis, saturation, definite resolution, the synchronizing control system has high synchronizing accuracy designed with the digital valve. To obtain the high accuracy, the PID control is introduced in the system. Both Simulation analysis and experiment make it clear that the synchronizing control system has high accuracy. The synchronizing control system has good performance. It can be applied widely in practice.

Acknowledgements

This project is supported by National Natural Science Foundation of China (No. 50475118)

References

- [1] Merritt, H. E. 1967 *Hydraulic Control Systems* (New York: John Wiley & Sons)
- [2] Ruan Jian 2000 *Electro-hydraulic (pneumatic) Direct Digital Control*. (Hanzhou: Press of Zhejiang University)
- [3] Zhang Z W, Zhang F B and Wang G D 2003 An Synchronization Control Strategy Applied in Two Cylinders System and its Simulation *Machine Tool & Hydraulics* pp 232-239
- [4] Li D M, Nie C J, Li J and Zhao H X 2000 The Effects of Manufactural Error of Fixed Throttle of Dividing-combining Valve to Accuracy of Synchronous System *Journal of Shanghai Tiedao University* **21** pp 22-52