

## The Design of Wireless Sensor Network System Based on ZigBee Technology for Greenhouse

This article has been downloaded from IOPscience. Please scroll down to see the full text article.

2006 J. Phys.: Conf. Ser. 48 1195

(<http://iopscience.iop.org/1742-6596/48/1/223>)

View [the table of contents for this issue](#), or go to the [journal homepage](#) for more

Download details:

IP Address: 38.107.179.213

The article was downloaded on 21/02/2012 at 18:31

Please note that [terms and conditions apply](#).

# The Design of Wireless Sensor Network System Based on ZigBee Technology for Greenhouse

Y W Zhu, X X Zhong and J F Shi

The Engineering Of Optical And Electronic College, ChongQing University,  
ChongQing, 400044, China

E-mail: zhuyingwei@163.com

**Abstract.** Wireless sensor network is a new research field. It can be used in some special situation for signal collection, processing and transmitting. Zigbee is a new Wireless sensor network technology characteristic of less distance and low speed. It is a new wireless network protocol stack of IEEE 802.15.4. Lately traditional system to collect parameters for Greenhouse is widely used in agriculture. The traditional system adopts wired way wiring, which makes the system complex and expensive. Generally modern Greenhouse has hundreds of square meters and they may plant variety of plants depending on different seasons. So we need to adjust the sensors which collect parameters for Greenhouse to a better place to work more efficient. Adopting wireless way wiring is convenient and economical. This paper developed a wireless sensor network system based on ZigBee technology for greenhouse. It offers flexibility and mobility to save cost and energy spent on wiring. The framework hardware and software structure, related programming are also discussed in this paper. Comparing the system which uses ZigBee technology with traditional wired network system for greenhouse, it has advantage of low cost, low power and wider coverage. Additionally it complies with IEEE802.15.4 protocol, which makes it convenient to communicate with other products that comply with the protocol too.

## 1. Brief Introduction to ZigBee Technology

ZigBee is a new technology now being deployed for wireless sensor networks. A sensor network is an infrastructure comprised of sensing, computing and communications elements that allows the administrator to instrument, observe and react to events and phenomena in a specified environment. Typical applications include, but are not limited to, data collection, monitoring, surveillance and medical telemetry. The administrator typically is a civil, government, commercial or industrial entity. The main advantages of ZigBee technology lies in the following aspects: (a) Reliable and self configuration. (b) Supports large number of nodes. (c) Easy to deploy. (d) Very long battery life. (e) Secure. (f) Low cost. (g) Can be used globally.

## 2. Wireless Sensor Network System for Greenhouse

### 2.1. System Framework for greenhouse

Every greenhouse in this system comprises a gateway and some wireless nodes. Gateways and nodes are all embedded with a CC2420 RF transceiver (ZigBee compliant) produced by Chipcon company.

Data can be transmitted by transceiver between gateways and nodes, and finally the data from all greenhouses are collected to be transmitted to a server. The sketch of the system is shown in Figure 1.

The framework and functions of the system lies in the following:

Functions of gateway:

- (1) Communicating with the server via Ethernet;
- (2) Communicating with nodes by RF transceiver.

Framework and functions of wireless nodes:

- (1) Atmega128L MCU and TinyOS operating system;
- (2) Temperature, humidity and light intensity collection periodically;
- (3) Transmitting collected data to gateway by using CC2420.

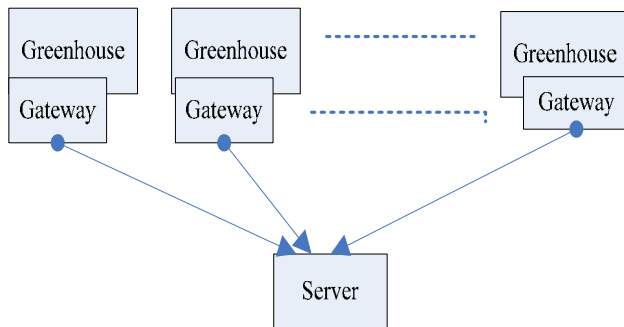

**Figure 1.** the Framework of Wireless Sensor Network for Greenhouse.

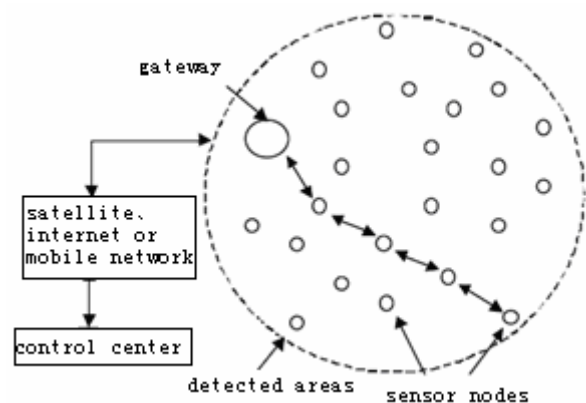

**Figure 2.** Typical Framework of Wireless Sensor Network.

## 2.2. The Framework of Wireless Sensor Network

The Framework of Wireless Sensor Network is shown in Figure 2. Each node can sense, compute and communicate each other. They can either receive message or transmits message, and can transmit messages to a gateway via self-configuration and multi-hop routing. The gateway can use many ways to communicate with remote network, such as Internet, satellite and mobile communication network (in this system we use Ethernet). More than one gateway may be used for large-scale application. Because of its limited communication areas the node must use multi-hop routing to access the nodes out of communication areas.

## 3. Hardware of Wireless Node

The wireless sensor network nodes use battery power and their power capabilities are limited due to its small size of node. The transmission rate of the network is low and it needs enough power to work steadily for a long time. Therefore low-power design is significant.

The system adopts MICAz mote module produced by Crossbow Technology and its sketch of hardware is shown in Figure 3. MICAz is embedded with a ZigBee compliant RF transceiver and it works between 2.4 and 2.4835 GHz, a globally compatible ISM band. Its DDSS radio offers both high speed (250 kbps) and hardware security (AES-128). The MICAz 51-pin expansion connector supports Analog Inputs, Digital I/O, I2C, SPI and UART interfaces. These interfaces make it easy to connect to a wide variety of external peripherals, including a variety of sensor, data acquisition boards and gateway.

### 3.1. Microcontroller

We adopt Atmega128L, a High-performance, and Low-power AVR 8-bit Microcontroller as our processor. The ATmega128 provides the following features: 32 general purpose working registers connected to ALU directly, On-chip 2-cycle Multiplier, 128K bytes of In-System Programmable Flash

with Read-While-Write capabilities, 4K bytes EEPROM, 4K bytes SRAM, 2 USARTs, an SPI serial port linked to CC2420, a byte oriented Two-wire Serial Interface, an 8-channel, 10-bit ADC with optional differential input stage with programmable gain, and it design six sleep modes, especially for the restriction of power.

### 3.2. RF transceiver

The CC2420 is the industry's first single-chip 2.4 GHz RF transceiver compliant with the IEEE 802.15.4 standard and already to be used in ZigBee products. In a typical application CC2420 will be used together with a microcontroller and a few external passive components. CC2420 set its work modes by SPI(SI, SO, SCLK, CSn) and achieve its read-while-write operation. The sketch of link between CC2420 and microcontroller is shown in Figure 4.

### 3.3. Gateway

MIB600CA which is one of MICAz mote developer's kits is adopted as a gateway for TCP/IP-based Ethernet. MIB600CA is used as a bridge to link the wired and wireless network. It connects the MICAz to Ethernet and permit server access data from wireless sensor network by TCP/IP-based Ethernet.

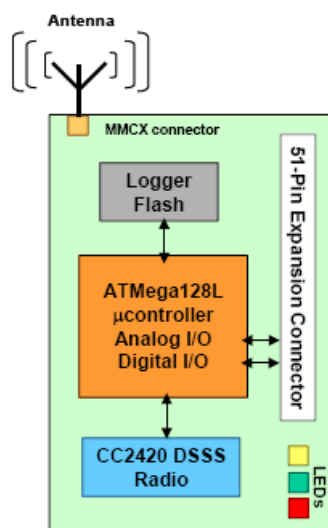

Figure 3. Hardware Framework of MICAz.

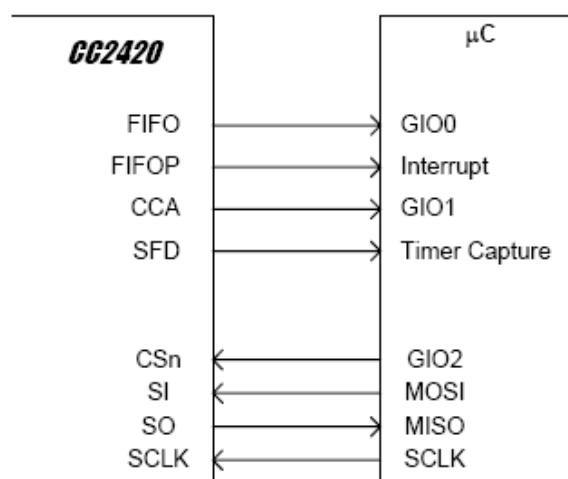

Figure 4. Link between CC2420 and microcontroller.

## 4. Brief Introduction to TinyOS

TinyOS is an event-driven operating system designed for sensor network nodes that have very limited resources (the core OS requires 400 bytes of code and data memory, combined). TinyOS supply a series of components which can be used to program conveniently and easily to acquire and process data acquired by sensors. We can regard TinyOS as a API interface interacted with sensors and they can communicate each other.

The TinyOS system, libraries, and applications are written in nesC, a new language for programming structured component-based applications. nesC is an extension to C, designed to embody the structuring concepts and execution model of TinyOS. The basic concepts behind nesC are:

(1) nesC is a "static language". There is no dynamic memory allocation and the call-graph is fully known at compile-time. These restrictions make whole program analysis and optimization significantly simpler and more accurate.

(2) Programs are built out of components, which are assembled ("wired") to form whole programs. Components can use or provide interface.

(3) Interfaces are only point of access to components. The interface specifies a set of named functions, called commands, to be implemented by the interface’s provider and a set of named functions, called events, to be implemented by the interface’s user. Interfaces are bidirectional and the user who uses the command must implement command.

(4) There are two types of components in nesC: modules and configurations. Modules provide application code, implementing one or more interfaces. Configurations are used to wire other components together, connecting interfaces used by components to interfaces provided by others.

(5) Components are statically linked to each other via their interfaces. This increases runtime efficiency and allows for better static analysis of programs.

**5. The Design of Software**

The wireless node’s applications are written in nesC. The software’s flow chart is shown in Figure 5.

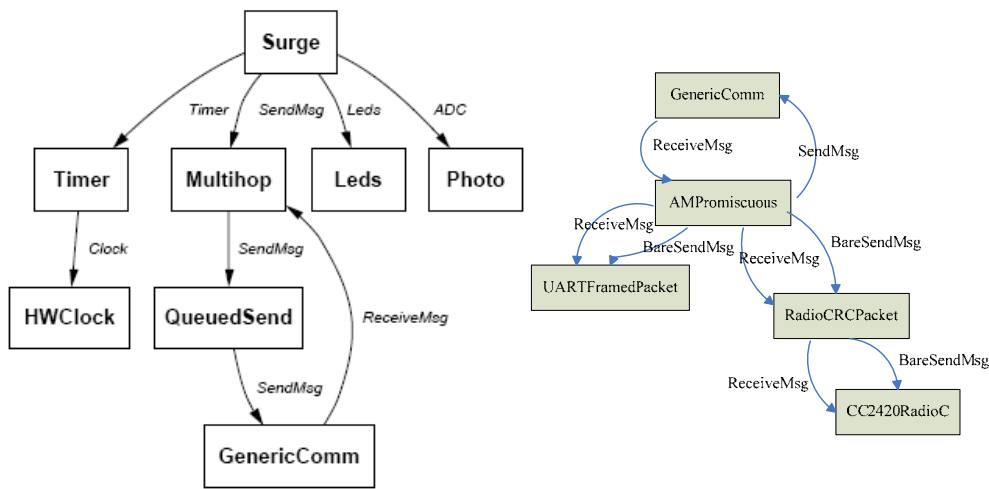

**Figure 5.** the Flow Chart of Application.

Figure 5 shows most components of application. The downward-pointing arrows depict commands and upward-pointing arrows depict events. Timer is an interface to supply a counter to generate an interrupt at a very interval. ReceiveMsg and BareSendMsg are all interfaces to receive messages from network, while SendMsg sends messages to network.

Multihop is a module for the judge of multi-hop. It receives messages from application and network and does some necessary sensing and transmitting. For example, if a node A want to communicate to a node B which is not at the range A can communicates, and another node C can communicate with A and B. At the moment the module-Multihop let A send message to C and C send the message to B. QuenedSend and GenericComm are communication modules which are responsible for communication in network layer. AMPromiscuous is a module to represent equipments and it can determine whether to send messages to UART or CC2420. RadioCRCPacket and CC2420RadioC which make RF transmitter send or receive messages represent the flow to CC2420. UARTFramedPacke’s flow represents messages to UART (gateway). The gateway’s function is to receive data and send data to server which will do more procession for those data.

**6. Experiment**

An experiment was done in a room which 11 meters in length and 8 meters in width. The application to measure temperature, light intensity, node voltage and parent node is written in Visual C ++6.0 under the Windows 2000 operation. Parent node denotes nodes that receive a message from another node and the 0 parent node represents base node (gateway). The result of experiment is shown in Figure 6

From Figure 6, we can see that the experiment measure parameters in room perfectly.

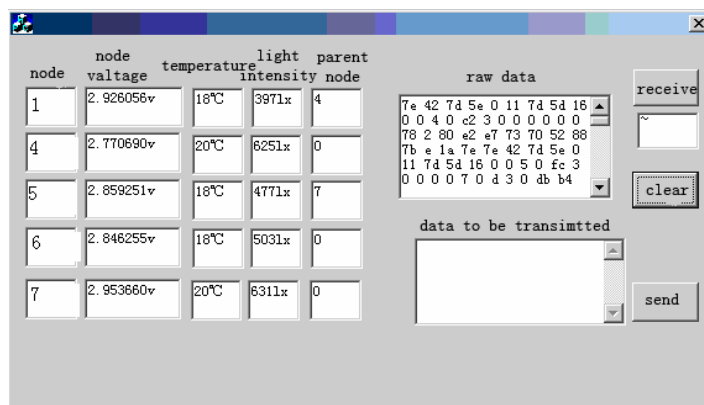

Figure 6. the Data of Experiment.

## 7. Conclusion

This paper present a wireless sensor network system based on ZigBee technology for greenhouse, exploring its system framework and technology characters. The experiment was also done to prove its feasibility. The system possesses low cost, low power, wider coverage, and especially the character of mobility on wiring to remove the limitation of traditional wired network system for greenhouse. Therefore the traditional system to collects parameters for Greenhouse would be greatly changed.

## References

- [1] Jianliang Zheng and M.J. Lee 2004 Will IEEE 802.15.4 make ubiquitous networking a reality? *IEEE Communications Magazine* **42** 140-146
- [2] David Gay, Phil Levis and Rob von Behren 2003 The nesC Language: A Holistic Approach to Networked Embedded Systems *Proceedings of Programming Language Design and Implementation (San Diego)* pp 1-11
- [3] Z. Wan, W. Taha and P. Hudak 2001 Event-Driven FRP. *In Proceedings of the Internation Symposium on Principles of Declarative Languages (Nevada)* pp 155-172