

Implementation of a Sample Turntable in Optical Scatter Measurement

This article has been downloaded from IOPscience. Please scroll down to see the full text article.

2006 J. Phys.: Conf. Ser. 48 983

(<http://iopscience.iop.org/1742-6596/48/1/183>)

View [the table of contents for this issue](#), or go to the [journal homepage](#) for more

Download details:

IP Address: 38.107.179.214

The article was downloaded on 14/02/2012 at 17:30

Please note that [terms and conditions apply](#).

Implementation of a Sample Turntable in Optical Scatter Measurement

C Qi^{1,2}, S Z Cheng² and G L Zhao¹

¹ Harbin Engineering University, Harbin 150001, China

² Harbin Institute of Technology, Harbin 150001, China

E-mail: qichao@hit.edu.cn

Abstract. The concept and the measuring principle of BSDF (bi-directional scattered distribution function) are analyzed. According to the single reference standard measuring principle, a set of system based on personal computer for BSDF measurement is developed, which laser wavelengths range from visible to far infrared. Considering the error of the receiver view angle and the total scattering zenith angle, the uncertainty of this device is 0.75%. The experiments about the hemispherical reflectance measurements on the aluminium at $\theta_1=30^\circ, \varphi_1=30^\circ$ and the granite at $\varphi_1=0^\circ$ were made when the incident angle is different, and the results shows that the effect of specular reflection is very obvious, the surface scattering is chief, and the whole surface tends to smoothly.

1. Introduction

Objectively the surface of any material is not ideal glazed plane or Lambertian. That is any beam of light illuminating to the material surface is neither complete mirror reflection nor absolute diffusion reflection. Spatial reflected intensity distribution coming from the illuminated uniform and isotropic material surface is an oval sphere using the mirror reflection direction as its axes. The spatial reflected characteristic and spectral characteristic of material surfaces are best described by the BRDF (bi-directional reflectance distribution function). Also, even the best optical glasses, fabricated using the best state-of-the-art (SOTA) polishing techniques, have small and local variation in their refractive indices. This effect causes a refractive scatter on the transmission. So BTDF (bi-directional transmittance distribution function) was introduced reasonably. Obviously, BTDF is very similar with BRDF in the concept, therefore their measurements and the calibrations should also be very alike. The more general optics quantity — BSDF [1] (bi-directional scattered distribution function) was defined.

The western countries (America, Canada, Germany et al.) with the advanced science and technology have done the research from the 1970s [2-4], while our country studied BRDF/BTDF quite late. At that time, several kinds of BRDF/BTDF turntable in abroad realized the changes in the “incident” and “scattering” directions all by revolving the detector and changing the position of laser. Its advantage was visual and simple for processing data. But the disadvantages were uncompact configuration, the built-in space track scale made the far field measurement difficult and couldn't be controlled by the computer easily. In our country, the BRDF turntable was designed in the end of 1980s, by Anhui Institute of Optics and Fine Mechanics, a branch of Chinese Academy of Sciences adopts that the detector was fixed in the distance and step motor turned the holder with laser source and sample, this structure was suitable for single wave band scattering measurement. In the end of last

century, Xidian University and Changchun Institute of Optics and Mechanics which is the branch of Chinese Academy of Sciences researched on BRDF measurement experiment in visible light or UV and VUV range one after the other [5,6]. Considering our country doesn't have the turntable for BRDF/BTDF measuring experiment in many laser wave band , so we develop this work.

2. BSDF

The BSDF is defined as the ratio of two infinitesimals [7]

$$f_S(\theta_i, \varphi_i; \theta_S, \varphi_S) = \frac{dL_S(\theta_i, \varphi_i; \theta_S, \varphi_S)}{dE_i(\theta_i, \varphi_i)} \tag{2.1}$$

Where dE —— the incident irradiance of an infinitesimal area from direction (θ_i, φ_i) .

dL —— the reflected/ transmittance radiance into an infinitesimal detector size with the detector area from direction (θ_S, φ_S) .

θ and φ ——zenith and azimuth angles in normal spherical coordinates, respectively

“i” and “s” subscripts refer to incident and reflected/ transmittance directions respectively. Figure1 depicts the beam and sample geometry of BRDF/BTDF.

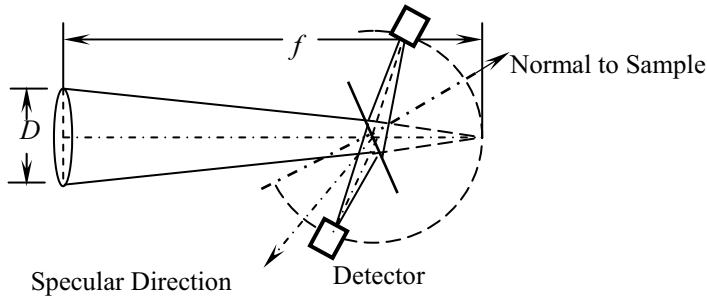

Figure 1. BRDF/BTDF geometry.

The $f_S(\theta_i, \varphi_i; \theta_S, \varphi_S)$ is approximately the constant of non-zero intervals in concrete BSDF measurement, it can be found from the following expression

$$L_S(\theta_i, \varphi_i; \theta_S, \varphi_S) = f_S(\theta_i, \varphi_i; \theta_S, \varphi_S) \int L_i(\theta_i, \varphi_i) d\Omega_i = f_S(\theta_i, \varphi_i; \theta_S, \varphi_S) E_i(\theta_i, \varphi_i) \tag{2.2}$$

Where $d\Omega_i$ is the unit projective solid angle. Then equation (2.1) can be written in the following form

$$f_S(\theta_i, \varphi_i; \theta_S, \varphi_S) = \frac{L_S(\theta_i, \varphi_i; \theta_S, \varphi_S)}{E_i(\theta_i, \varphi_i)} \tag{2.3}$$

There are two forms for BSDF measuring, absolute measuring and relative measuring. Absolute measuring is making without any reference standard. But relative measuring is comparing the reference standard of the known reflectance with the sample. Because the relative measuring eliminates the stray light and reduces the error effectively, it saves time and energy, and is most popularly used, it can be divided as substitution measuring method and single reference standard measuring method. In this paper, according to the single reference standard measuring principle (2.4) [8], a sample turntable for BSDF measurement is developed.

$$f_S = f_r \cdot \frac{V_S}{V_r} \cdot \frac{\cos \theta_r}{\cos \theta_S} \tag{2.4}$$

where f_S, f_r ——denote the measured BSDF values of the sample and the reference, respectively ;

V_S, V_r ——denote the scattered power by the sample and by the reference onto the detector respectively;

θ_S, θ_r ——denote the received zenith angle of the sample and the reference standard versus the detector.

3. Turntable

3.1. Design of a sample turntable

The experimental sample turntable with three freedoms for BSDF measurement is designed, as shown in figure2, in which the laser wavelengths range from visible $0.6328\mu\text{m}$ to far infrared $10.6\mu\text{m}$.

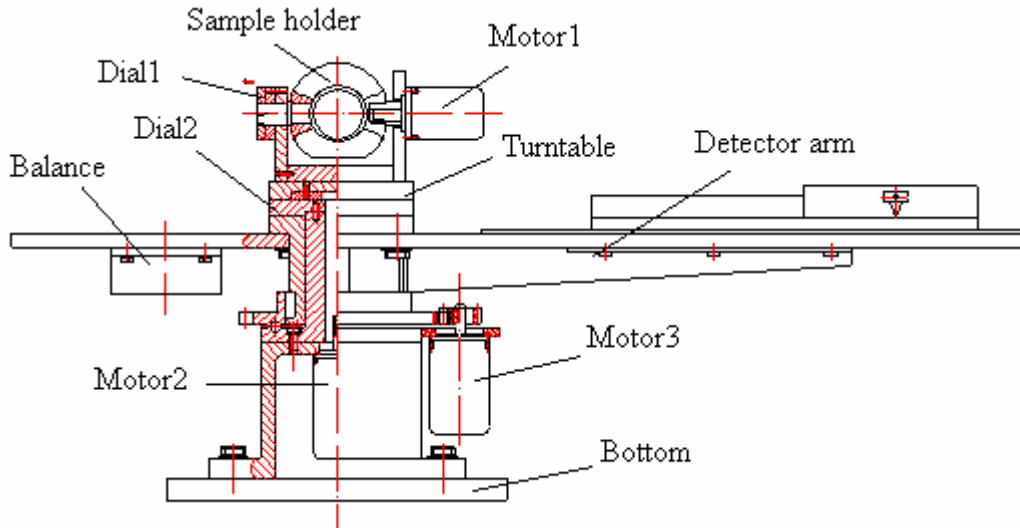

Figure 2 .The sample turntable for the BSDF measurement.

The crankshaft of the No.1 motor is parallel to the table-board, and is perpendicular to the normal of the sample plane, drives the sample running within $-90^{\circ}\sim+90^{\circ}$. At the same time, the crankshaft of the No.2 motor intersects the crankshaft of the No.1 in the center of the sample, plumbs in the bottom, and drives the No.1 motor and the sample rotating together. It is obvious that the direction of the No.1 crankshaft is variable in the space plane in the course of running. In addition, the scope that the No.2 motor drives the sample turntable running also is $-90^{\circ}\sim+90^{\circ}$, the angles of sloping running and rotating are indicated by the dial 1 and dial 2 respectively. The No.1 motor combines the No.2, that can realize the changes of the incident zenith angle θ_i and azimuth φ_i . The No.3 crankshaft is parallel to the No.2, drives the detector arm rotating about the turntable axis within $-180^{\circ}\sim+180^{\circ}$ via a decelerating gear. So the scattered radiance which comes from the sample can be measured as the function of space scattered angle (θ_s, φ_s) . The control of the sample direction and the acquisition of the measuring data are completed by the computer automatically, therefore we can start the research on the space scattering property and spectral characteristic of objective material.

3.2. error analysis of sample turntable

For spatial diffusion and non-mirror scattered measurements, $\varepsilon_{\text{BSDF}}$ of the turntable can be evaluated and expressed by the following equation [9]

$$(\varepsilon_{\text{BSDF}})^2 = (\varepsilon_{\text{SLD}})^2 + (\varepsilon_{\theta_S} \tan \theta_S)^2 \quad (3.1)$$

Where ε_{SLD} is the error of the receiver view angle, ε_{θ_S} is the error of the total scattering zenith angle and θ_S is the receiver scattering zenith angle. The error of the receiver solid angle, ε_{SLD} is

$$(\varepsilon_{\text{SLD}})^2 = (2\varepsilon_{\text{RM}})^2 + (2\varepsilon_{\text{RZ}})^2 + (2\varepsilon_{\text{RA}})^2 \quad (3.2)$$

Where ε_{RM} is the error in the goniometer receiver arm radius, ε_{RZ} is the error of the receiver arm radius due to the sample Z direction misalignment, and ε_{RA} is the error of the receiver aperture size. The total scattering zenith angle error, ε_{θ_S} , is given by

$$(\varepsilon_{\theta_S})^2 = (\varepsilon_{\theta_M})^2 + (\varepsilon_{\theta_Z})^2 + (\varepsilon_{\theta_T})^2 \quad (3.3)$$

Where $\varepsilon_{\theta M}$ — the error of the goniometer scattering angle;
 $\varepsilon_{\theta Z}$ — the error due to sample Z -direction misalignment;
 $\varepsilon_{\theta T}$ — the sample tilt error.

Obviously, if each of the errors is considered by oneself, the BSDF turntable error can be gotten. Based on our own developed automation BSDF measurement system, the solid angle error of the receiver is a function of three errors. The first is due to the error in the goniometer's receiver arm radius. Detector cantilever is 600mm long, mechanical processing error is 0.3mm. The error caused by the second sample Z direction misalignment can be calculated by 1°; The last component of the solid angle error comes from the size of the receiver's aperture. By exercising great care in the design of the electro-optical system of the receiver, then we can make the mechanical aperture be the actual aperture. The actual aperture size was used with the 0.15% as the error. So according to expression (3.2), ε_{SLD} is about 0.7%.

Scattering zenith error $\varepsilon_{\theta S}$ is based on the angle error of the system, it can be taken as 0.072° equally within a circle caused by the rotating of the motor; the scattering zenith error caused by sample Z nonalignment is around 1°. Then according to express (3.3), $\varepsilon_{\theta S}$ is 0.28%.

Take above results into expression (3.1), then

$$\varepsilon = \sqrt{\varepsilon_{SLD}^2 + \varepsilon_{\theta S}^2} = \sqrt{0.7^2 + 0.28^2} \times 100\% \approx 0.75\% \tag{3.4}$$

4. Measurement

The experiments about the hemispherical reflectance measurements on the aluminium at $\theta_i=30^\circ, \varphi_i=30^\circ$ and the granite at $\varphi_i=0^\circ$ when the incident angle is different were made, as shown in figure3 and figure4 respectively.

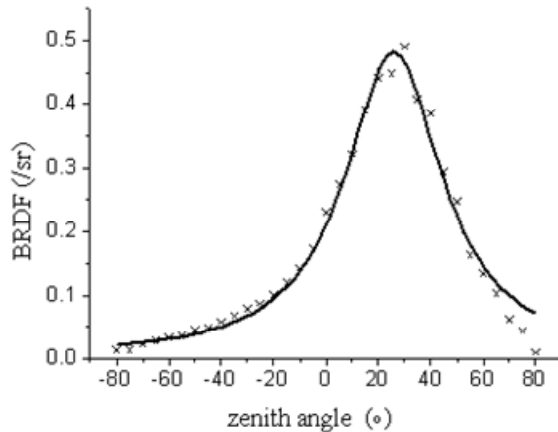

Figure 3. Results of BRDF measurements At $\theta_i=30^\circ, \varphi_i=30^\circ$.

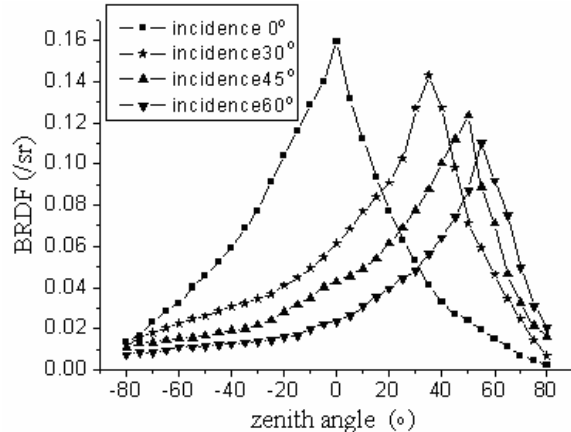

Figure 4. Results of BRDF measurements at $\varphi_i=0^\circ$.

As shown in figure3, the scattered angle to which the maximum corresponds is about the mirror reflection, the value in which direction is greatly bigger than others. So we can know that the metal aluminum surface tends to the smooth surface, the effect of specular reflection is very obvious and the surface scattering is chief in this wave band. But because of roughness, there is some scattering light in other directions. The experimental results are well agreement with the model, average deviation is less than 0.43%.

The changes of incident angle can influence the following three factors: incident luminous flux, reflectivity on the surface and shadowing effect. The figure4 shows that when the incident angle is option, there is a maximum value in the curve, besides the scattered angle to which the maximum corresponds is about the mirror reflection, and the peak value of curve shifts towards right along with the increase of incident angle. Especially, the peak value reduces as the incident angle increases, this is

because the surface is fairly gentle, the shadowing effect is not obvious and the effective incident flux is most important for the incident intensity. As a result of incident flux reduces along with incident angle increases, the corresponding mirror reflected intensity is lower and lower.

5. Conclusion

The equipment designed for BSDF measurement realizes the relative changes in the “incident” and “scattering” directions by fixing four laser sources, rotating the detector in the plane and changing the position of the sample, it realizes that hemispherical scattered measurements substitute for the whole spherical measurements conveniently, it saves not only time but also workload. Under the closed loop control, the accuracy of rotary angle can be limited within 0.036° and the relative error of this device is less than 0.75%. It is applicable to the research on BRDF/BTDF under the laser wavelengths range from visible $0.6328\mu\text{m}$ to far infrared $10.6\mu\text{m}$.

Acknowledgments

It is pleasure to thank Professor Chen Xi-you for his many helpful discussions.

Project (A2004-02) Supported by the Scientific Research Foundation and post doctor Foundation of Heilongjiang.

References

- [1] William L, Lawrence M S and Max K B 1986 Stray light analysis and suppression in small angle BRDF/BTDF measurement *SPIE* **675** 207-216
- [2] Michael M S, James A and Brian S 2005 Barycentric parameterizations for Isotropic BRDFs *IEEE* **11** 126-138
- [3] Rasim L, Josef C and chen J 2003 A comparison of BRDF models for the normalization of satellite optical data to a standard sun-target-sensor Geometry *IEEE* **41** 1889-98
- [4] Thomas R, Hendrik R and Ander K Design problems of a calibrated BRDF sensor with respect to dynamic range, speed and large angle of view *SPIE* **4100** 136-147
- [5] Wu Z S, Jiang R X, Han X E, Zhang X D, Wei Q N and Xu Z 1996 Experimental study on BRDF of laser scattering from various rough surfaces *ACTA OPTICA SINICA* **16** 262
- [6] Tang Y G, Qi W Z and Li F T 2000 Study of diffuser in UV and VUV range *ACTA OPTICA SINICA* **20** 267
- [7] Bartell F O, Dereniak E L and Wolfe W L 1980 The theory and measurement of BRDF and BTDF *SPIE* **257** 154-159
- [8] Qi C, Li W J, Wang Z G and Dai J M 2004 Application study of BRDF on measuring projectile position in multi-stage coilgun *3rd International Symposium on Instrumentation Science and Technology (Xi'an, China, August)* **18-22** 1363-66
- [9] Tod F S, Mary W K and Daniel J W 1993 Design review of a high accuracy UV to near IR scatterometer *SPIE* **1995** 121-128