

Nano-resonators for RF-enabled networked-control

This article has been downloaded from IOPscience. Please scroll down to see the full text article.

2006 J. Phys.: Conf. Ser. 38 158

(<http://iopscience.iop.org/1742-6596/38/1/038>)

View [the table of contents for this issue](#), or go to the [journal homepage](#) for more

Download details:

IP Address: 38.107.179.211

The article was downloaded on 15/02/2012 at 01:21

Please note that [terms and conditions apply](#).

Nano-resonators for RF-enabled networked-control

Lifeng Wang¹, Stephen M. Phillips¹, Michael S. Branicky², Bulent Bayraktar³

Electrical Engineering, Arizona State University, Tempe, AZ¹; Electrical Engineering and Computer Science, Case Western Reserve University, Cleveland, OH²; Electrical and Computer Engineering, Purdue University, West Lafayette, IN³.

stephen.phillips@asu.edu

Abstract. Several types of microfabricated mechanical filters are analyzed for RF communications applications and their advantages over the traditional SAW or FBAR filters are described. GHz frequency operation requires sub-micron dimensions. This work focuses on the modeling of a filter with torsional mode vibration. Ansys finite element simulation has been performed to make comparison with the analytical modelling. These devices enable a networked approach to control along with a specific application to velocity estimation in servocontrol.

1. Introduction

On-chip MEMS filters allow smaller circuit size and higher Q relative to discrete SAW or FBAR filters. The area is reduced from several square mm [1] to several hundred square μm [2]. This enables the fabrication of a bank of filters which may cover a large frequency range and have high speed channel switching. The high Q allows for novel transceiver architectures with low power consumption and high selectivity [3]. The high selectivity attenuates the adjacent channel interferers. This is important since the interaction of these interferers with downstream component (low noise amplifier, mixer and A/D converter) nonlinearities dominates the third order intermodulation distortion. This reduction allows a relaxation of the linearity requirements for these components.

Several types of MEMS filters have been reported ranging from clamped-clamped beam resonators, to free-free beams [4], to radial-mode disks [5]. For all of these resonators, an ac voltage is used to set the device into resonance and a dc voltage used to make slight frequency adjustments. Clamped-clamped beam resonate in the 100MHz range with Q's in the hundreds. Stiffening the device to achieve higher frequencies will reduce the Q due to increased coupling through the anchors to the substrate, an energy loss mechanism. The free-free beam structure reduces these anchor losses by placing them and the nodes of the beam bending oscillation. The smaller torsional forces allow Q's of 8000 at similar frequencies. The radial contour mode disk resonators can achieve GHz resonances with high Q although the fabrication is more complicated [6]. The goal of this work is to design a device with high performance along with a straightforward fabrication process.

Section 2 covers our device design, its analysis, and the insights into performance limitations. Section 3 shows its usefulness in networked control systems. Section 4 discusses an application to velocity estimation and Section 5 contains concluding remarks.

2. Device Design and Analysis

Proposed here is a resonant structure utilizing torsional vibration to achieve high frequency with high Q comparable to the beam structures, while reducing the complexity of the fabrication relative to the

disk resonators. Figure 1 shows a structure with a GaN structural layer, a PZT actuation layer with built-in charge separation, a gold electrode layer and an AlN insulating layer.

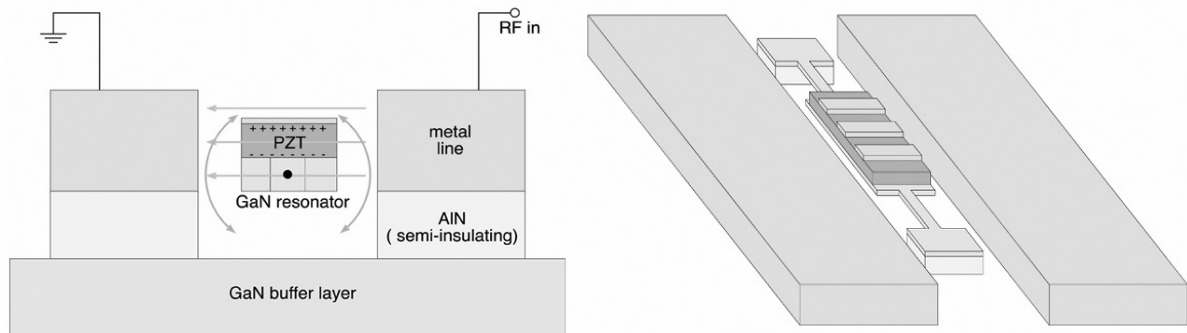

Figure 1. Nano-resonator structure cross-section and oblique view.

The incoming RF signal generates an oscillating electric field between the two electrodes. The interaction of this field with the PZT charges generates a torque. Since the mechanical structure does not have the symmetry about the axis of rotation, an undesired eccentric lateral vibration will couple to the desired torsional vibration. The vibration modes of one cross section is shown in Figure 2. The lower frequency mode is dominated by the lateral vibration and the higher frequency mode is dominated by the torsional vibration.

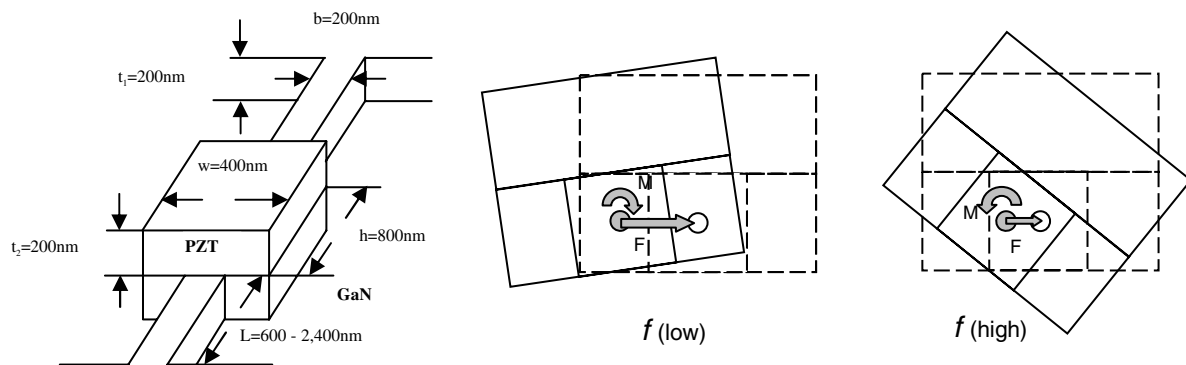

Figure 2. Device dimensions, lateral dominated and torsional dominated vibration modes.

The above analysis is suitable for a lumped element model. However, it can also be applied to a continuous mass distribution if its equivalent k , M , r , $k\theta$, I_c are calculated. For this, the displacement and velocity of the cross section at the center of the structure are used for reference and the lumped mass parameters are adjusted to match the energy of the deformed suspending beam structure to that of the lumped model. Using this method the influence of the device dimensions on the mode frequency and the ratio of the lateral to torsional motion (x/θ) can be computed as shown in Table 1.

These relatively large devices were designed, analyzed, and simulated to allow quick prototyping in a standard MEMS process to confirm these methods. Ultimately the resonators must be smaller to achieve GHz resonances. In collaboration with the Jet Propulsion Laboratory, fabrication of submicron resonators has begun and a structure without electrodes is shown in Figure 3. The shape of this structure was motivated by the analyses that we completed and should achieve GHz resonances. These resonators will enable a reduction in wireless transceivers resulting in their proliferation in stand-alone devices such as individual sensors and actuators in control systems.

3. Networked Control Systems

Networked control systems (NCS), shown in Figure 4, have communications across networks which offer improvements in reconfigurability, fault tolerance, modularity, and overall data rate compared to control systems with dedicated communication channels [7,8]. Realizing these advantages requires management of the potentially performance-affecting and destabilizing delays due to network scheduling and congestion. Analysis of delay-tolerant control strategies and delay compensation schemes [9,10] as well as optimal control methods for linear systems have been established, and results give bounds on the sensor sampling intervals that ensure system stability. The advantages of considering network issues (e.g. bandwidth and scheduling) along with control issues (e.g. stability and performance) give rise to new design paradigms, such as co-simulation for co-design [11].

L (μm)	k (N/m)	M (kg)	r (m)	k_θ (N*m/rad)	I_c (kg*m^2)	f_1 (Mhz)	(X/Θ) ¹
0.6	2.15E+03	4.95E-16	9.83E-08	4.51E-11	1.26E-29	435.7	-2.337E-07
1.0	4.64E+02	5.31E-16	9.15E-08	2.71E-11	1.32E-29	252.2	-1.403E-07
1.4	1.69E+02	5.68E-16	8.56E-08	1.93E-11	1.37E-29	196.8	-1.064E-07
1.8	7.96E+01	6.04E-16	8.05E-08	1.50E-11	1.41E-29	167.4	-9.134E-08
2.2	4.36E+01	6.41E-16	7.59E-08	1.23E-11	1.46E-29	147.9	-8.237E-08
2.4	3.36E+01	6.59E-16	7.38E-08	1.13E-11	1.48E-29	140.2	-7.895E-08

Table 1. Analytical Analysis of Resonator Characteristics.

In a NEMS context, networked control systems enable the construction of a device that operates at a distance from its control architecture. As such, the device can use lower power, even if subjected to more complex control strategies. More complex control strategies can be achieved by leveraging remote computational power, including global feedback information, and collecting enterprise level statistics. A proposed architecture for an NCS test-bed involves a mobile agent performing laser target tracking. In this case, the control communication is performed across a wireless network, allowing for the agent, controller, and separate scout sensing agents to be spatially distributed. This provides NCS functionality while allowing the study of issues involving the delays between sensors, controller, and actuators.

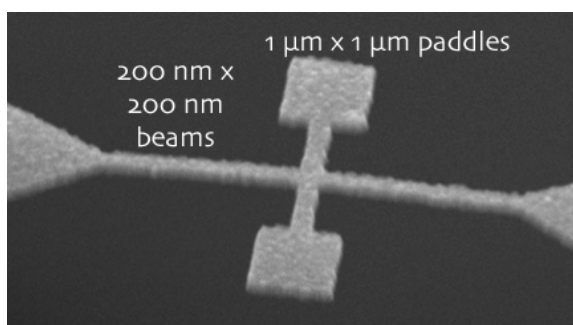

Figure 3. Nanoscale Resonator

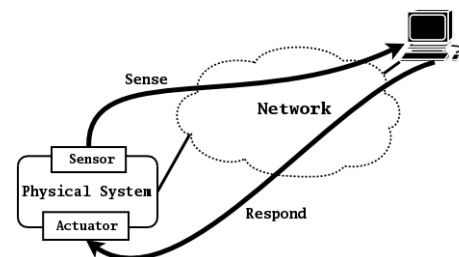

Figure 4. Networked Control System

As a further embodiment of the NCS environment we consider the application to a velocity estimation problem often encountered in servo control or motion tracking using optical encoders. A critical issue for these devices is the event-driven nature of the timing of their measurements.

4. Velocity Estimation with Encoders

The performance of motion control can be improved with accurate position and velocity feedback. The commonly used encoder is a position detector that generates a pulse when it is displaced by a fixed distance or angle and is used as a velocity detector either by counting the position pulses over a time interval (fixed-time or FT) or by measuring the time between pulses (fixed-displacement or FD). The physical mechanism suggests an event-driven measurement in which the position information is updated whenever a pulse is generated [12]. This is contrary to most control system methodologies in which measurements are made according to a fixed sampling schedule.

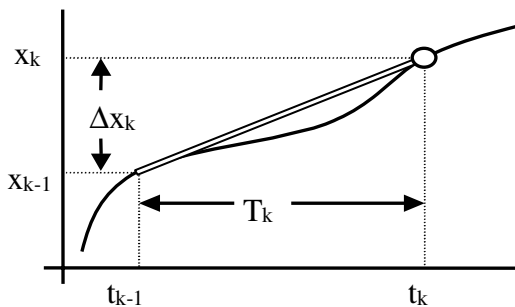

Figure 5. Position Encoder Sampling

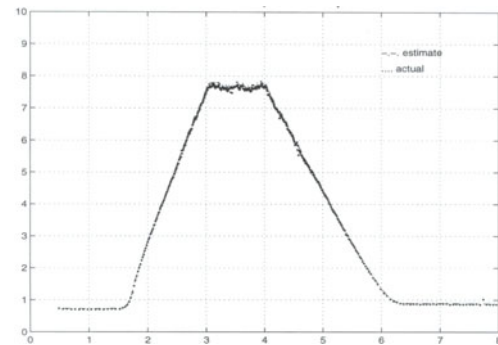

Figure 6. Improved Velocity Estimates

At the k th sampling instant, we have the time, t_k , and the position traveled, x_k , available as in Figure 5. For velocity, the derivative is approximated based on this quantized position and time data, a process which inherently tends to magnify errors or noise. One mitigation approach is to create an estimator that manipulates the most recent n position/time data points [13]. Such an estimator necessarily has some group delay which can reduce the relative stability of a feedback system [14]. Also, a higher order might improve the performance of the estimator in fitting the gathered data, but may increase measurement errors.

The first-order approximations for velocity estimation are the LPP (lines-per-period, FT) estimator which counts pulses per time period $T_k = t_k - t_{k-1}$, and the RT (reciprocal-time, FD) estimator which measures time between pulses $\Delta x_k = x_k - x_{k-1}$. These velocity estimates are the *average* velocities over the sampling intervals, not the true velocities at the samples. By using a Taylor series expansion higher order estimators are derived which closely resemble the higher-order data extrapolators or “holds” used in digital control. In contrast, least squares methods for FT estimators (LS-FT) are derived which avoid the sensitivity to measurement errors common with the extrapolation approaches.

Using simulation results for the FT and LS-FT methods, we conclude that FT methods have good transient response but are sensitive to position measurement quantization while LS-FT methods are better at near-constant velocities and are relatively insensitive to measurement quantization due to the smoothing effect of the least squares [15]. At low speed both the FT and LS-FT methods are poor due to the relatively infrequent occurrence of position pulses. In contrast, the FD and LS-FD methods perform well at low velocities but poorly at high velocities due to the measurement truncation error. Similarly they are less tolerant of encoder imperfections such as position jitter. These conclusions demonstrate that no single estimation method is best for a system that has a large dynamic range of velocities, has large transients, and embodies an imperfect encoder (though the second order LS-FT is quite a versatile performer). Hence, the method to use is application-dependent and the choice should be guided by these general conclusions.

Although simulations are a useful guide, we explored analytical tools for evaluating the methods' performance. Specifically, we used floor operations [16] to derive worst-case error bounds for many of the methods in cases of constant velocity and constant acceleration profiles. Transient profiles are very difficult with this analytical approach and were not pursued. Not surprisingly, for these constant velocity and acceleration cases, the LS-FT methods achieved better worst-case performance bounds, consistent with the simulation studies.

Finally, we performed physical experiments using a 10,000 count/rev (measured position) and 360,000 count/rev encoder (“true” position), in a motor control set-up with a sampling period of 1ms and time resolution of 100 μ s [15]. As an example of the approach described here, a combined algorithm is used to demonstrate improved performance of a velocity estimator operating over a large range of both constant velocity and transient velocities as shown in Figure 6.

5. Conclusions

This paper describes the analysis of a nano-resonator for wireless communications applications. The analysis motivates a novel structure for the devices and predicts their performance. Networked control systems enabled by wide adoption of these wireless components are described. The paper describes a use of the networked control strategy for a velocity estimation application. Results of simulations, an analytical approach and an experimental setup show improved performance for velocity estimation with quantized position measurements.

The authors acknowledge support of the National Science Foundation under grant CCR-0329910.

References

- [1] T. Tagami, H. Ehera, K. Noguchi, and T. Komaski, “Resonator Type SAW Filter,” *Oki Tech. Rev.*, vol. 63, p. 59, 1997.
- [2] C. T.-C. Nguyen, “Micromechanical Circuits for Communication Transceivers,” *Bipolar/BiCMOS Circuits and Technology Meeting*, p. 142, 2000.
- [3] C. T.-C. Nguyen, “Frequency-selective MEMS for Miniaturized Low-Power Communication Devices,” *IEEE Trans. Microwave Theory and Techniques*, Vol. 47, N. 8, p. 1486, 1999.
- [4] Wang, A-C Wong, and C. T.-C. Nguyen, “VHF Free-Free Beam High-Q Micromechanical Resonators,” *J. of Microelectromechanical Sys.*, Vol. 9, No.3, p. 347, 2000.
- [5] J.R. Clark, W.-T. Hsu, and C. T.-C Nguyen, “High-Q VHF Micromechanical Contour-Mode Disk Resonators,” *Tech. Digest, IEEE Int. Electron Dev. Mtg*, San Francisco, p. 493, 2000.
- [6] J. Wang, Z. Ren, and C. T.-C Nguyen, “Self-Aligned 1.14-GHz Vibration Radial-Mode Disk Resonators,” *Transducers, 12th Int. Conf.*, 2003 , Volume: 2 , p. 947, 2003.
- [7] W. Zhang, M. S. Branicky, and S. M. Phillips, “Stability of Networked Control Systems,” *IEEE Control Systems Magazine*, 21(1):84-99, February 2001.
- [8] V. Liberatore, M. S. Branicky, S. M. Phillips, and P. Arora, *Networked Control Systems Repository*, <http://home.cwru.edu/ncs/>.
- [9] J. Nilsson, *Real-Time Control Systems with Delays*, Ph.D. dissertation, Department of Automatic Control, Lund Institute of Technology, Lund, Sweden, 1998.
- [10] M. S. Branicky, S. M. Phillips, and W. Zhang, “Scheduling and Feedback Co-design for Networked Control Systems,” *Proc. IEEE Conf. on Decision and Control*, Las Vegas, 2002.
- [11] M. S. Branicky, V. Liberatore, S. M. Phillips, “Networked Control System Co-simulation for Co-design,” *Proc. American Control Conf.* Denver, CO, USA, June, 2003.
- [12] R.H. Brown and S.C. Schneider, “Velocity Observations from Discrete Position Encoders,” *Proc. IECON'87*, vol. 6, pp. 1111-1118, Cambridge, MA, Nov. 1987.
- [13] R.H. Brown, S.C. Schneider, and M.G. Mulligan, “Analysis of Algorithms for Velocity Estimation from Discrete Position versus Time Data,” *IEEE Transactions on Industrial Electronics*, vol. 39, no. 1, pp. 11-19, Feb. 1992.
- [14] P.S. Carpenter, R.H. Brown, et al., “On Algorithms for Velocity Estimation Using Discrete Position Encoders,” *Proc. IECON'95*, pp. 844-849, Orlando, FL, Nov. 1995.
- [15] B. Bayraktar, *Velocity Estimation Using Quantized Measurements: Theory and Experiments*, M.S. Thesis, Case Western Reserve University, 1999.
- [16] R.L. Graham, D.E. Knuth, O. Patashnik, *Concrete Mathematics*, Chap. 3, Reading, MA: Addison-Wesley, 1994.