

OPEN ACCESS

A study for high accuracy measurement of residual stress by deep hole drilling technique

To cite this article: Houichi Kitano *et al* 2012 *J. Phys.: Conf. Ser.* **379** 012049

View the [article online](#) for updates and enhancements.

You may also like

- [Identifying ADHD boys by very-low frequency prefrontal fNIRS fluctuations during a rhythmic mental arithmetic task](#)
Sergio Ortuño-Miró, Sergio Molina-Rodríguez, Carlos Belmonte et al.
- [Resting state dynamic functional connectivity in children with attention deficit/hyperactivity disorder](#)
Maliheh Ahmadi, Kamran Kazemi, Katarzyna Kuc et al.
- [Subtype classification of attention deficit hyperactivity disorder with hierarchical binary hypothesis testing framework](#)
Yuan Gao, Huaqing Ni, Ying Chen et al.



ECS
The
Electrochemical
Society
Advancing solid state &
electrochemical science & technology

DISCOVER
how sustainability
intersects with
electrochemistry & solid
state science research

A study for high accuracy measurement of residual stress by deep hole drilling technique

Houichi Kitano, Shigetaka Okano and Masahito Mochizuki

Graduate School of Engineering, Osaka University, 2-1 Yamada-oka, Suita, Osaka
565-0871, Japan

E-mail: h-kitano@mapse.eng.osaka-u.ac.jp

Abstract. The deep hole drilling technique (DHD) received much attention in recent years as a method for measuring through-thickness residual stresses. However, some accuracy problems occur when residual stress evaluation is performed by the DHD technique. One of the reasons is that the traditional DHD evaluation formula applies to the plane stress condition. The second is that the effects of the plastic deformation produced in the drilling process and the deformation produced in the trepanning process are ignored. In this study, a modified evaluation formula, which is applied to the plane strain condition, is proposed. In addition, a new procedure is proposed which can consider the effects of the deformation produced in the DHD process by investigating the effects in detail by finite element (FE) analysis. Then, the evaluation results obtained by the new procedure are compared with that obtained by traditional DHD procedure by FE analysis. As a result, the new procedure evaluates the residual stress fields better than the traditional DHD procedure when the measuring object is thick enough that the stress condition can be assumed as the plane strain condition as in the model used in this study.

1. Introduction

Residual stresses are found in weld joints because of the localized heat input, the difference between the expansion coefficients of joint members, and the restraints around welded zones. In particular, high residual tensile stresses occur near welded zones. These stresses can affect the fracture and fatigue behaviours in welded structures¹. Therefore, residual stresses in welded structures should be assessed in detail for the appropriate design, production, and maintenance. These are necessary for environmental consciousness of welded structures. For this purpose, the inner residual stress fields are as important as surface residual stress fields. The neutron diffraction technique is a well-known evaluation method of inner residual stress fields². However, it is not always possible to conduct the evaluations with this technique easily because it requires huge experimental facilities and a stress-free sample. In addition, this technique cannot be applied to the residual stress evaluation of plates more than several tens of millimetres in thickness. Therefore, a new technique for evaluating inner residual stress fields is needed when the neutron diffraction technique cannot be applied.

Consequently, the deep hole drilling (DHD) technique has received much attention in recent years as a method for measuring through-thickness residual stresses³⁻⁵. The DHD technique measures the diametric change of a reference hole drilled thorough the component between before and after the residual stress release. The residual stress release is performed by trepanning a column of material containing the reference hole. The DHD technique has some advantages over the neutron diffraction

technique, such as simpler test devices and procedures, applicability to thick plates, and in-field testing. Therefore, the DHD technique has merits that differ from those of the neutron diffraction technique.

However, some accuracy problems relevant to the appropriate design, production, and maintenance of structures occur when residual stress evaluation is performed by the DHD technique. The reason is the traditional DHD evaluation formula applies to the plane stress condition. In addition, the effects of plastic deformation produced in the DHD process are ignored. These can affect the accuracy of the evaluation results obtained by the DHD technique. Therefore, the traditional DHD evaluation procedure does not perform actual precise evaluation of the residual stress fields.

In this study, a new evaluation procedure is discussed for the high accuracy evaluation of residual stresses by the DHD technique.

2. Traditional DHD technique

Figure 1 provides a schematic illustration of the measurement method, which consists of following four experimental steps:

- Step 1 A reference hole is drilled through the specimen with a gun drill.
- Step 2 The initial diameters d_0 of this hole are measured accurately at several depths and angles using an air probe.
- Step 3 A column of material containing the reference hole as its axis is coaxially freed using electro-discharge machining (EDM).
- Step 4 The final diameters d of the reference hole are re-measured at the same depths and angular positions as those in step 2.

Let the direction of drilling the reference hole is denoted by z -axis, the depth from the top of the reference hole is denoted z , the angle from the x -axis is denoted by θ , (See Figure 1(e)) the differences between d_0 and d at depth z and angle θ is denoted by Δd and the normalized diametric distortion $\Delta d/d_0$ is denoted by $u_r(z, \theta)$. The relationship between $u_r(z, \theta)$ and remote stress fields σ_x , σ_y , σ_{xy} is given by the elastic solution for a hole in an infinite plate, as follows⁶:

$$\begin{aligned} u_r(z, \theta) &= \frac{d(z, \theta) - d_0(z, \theta)}{d_0(z, \theta)} = \frac{\Delta d(z, \theta)}{d_0(z, \theta)} \\ &= -\frac{1}{E} [(1 + 2 \cos 2\theta)\sigma_x + (1 - 2 \cos 2\theta)\sigma_y + 4 \sin 2\theta \sigma_{xy}], \end{aligned} \quad (1)$$

where E is Young's modulus. Therefore, three $u_r(z, \theta)$ - θ relationships at each depth give one evaluation result of σ_x , σ_y , σ_{xy} .

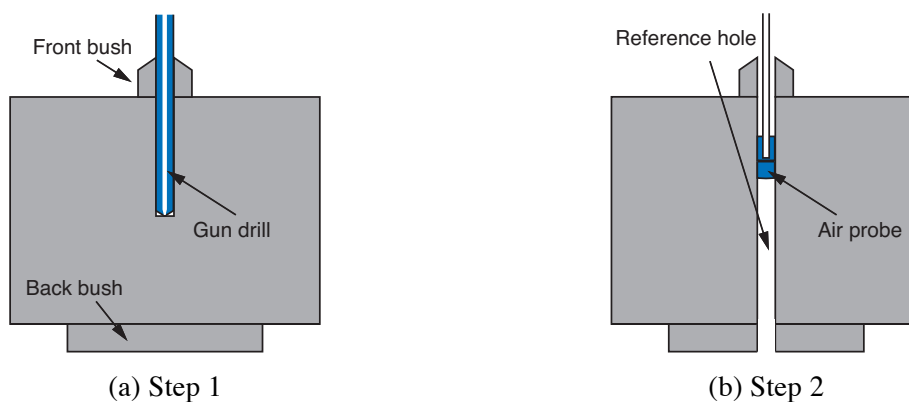

Figure 1. Steps in the DHD technique.

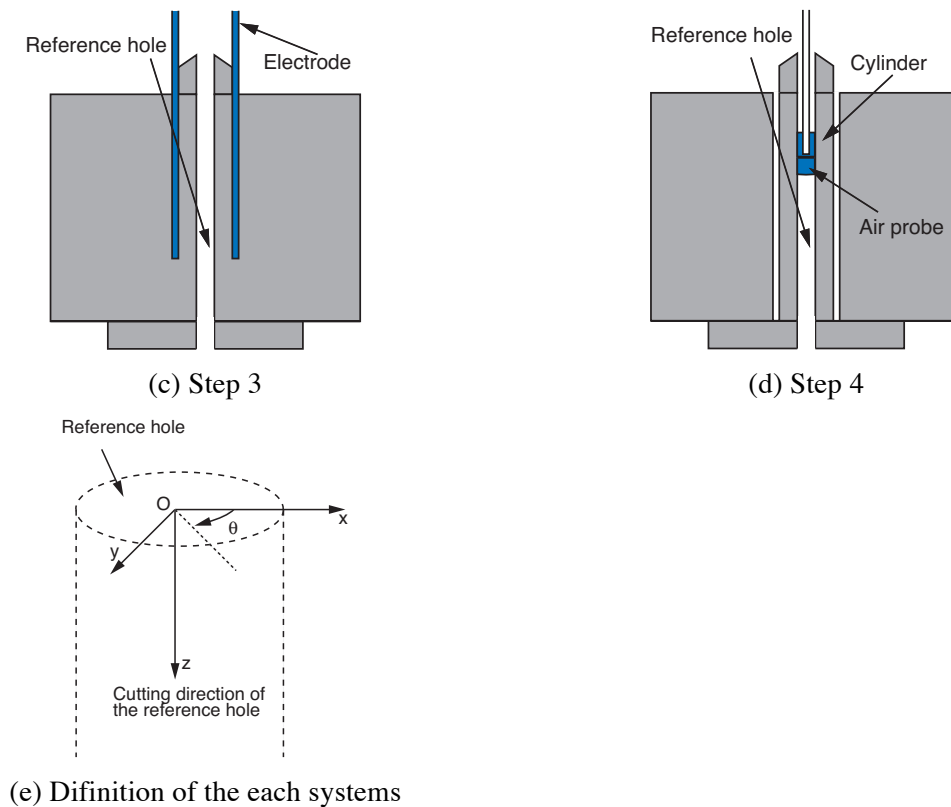

Figure 1. Continued.

3. Modification of the evaluation formula

The traditional evaluation formula applied to the plane stress condition. However, when inner residual stress fields are evaluated, the stress condition around the reference hole is close to the plane strain condition. Therefore, the diametric change of the reference hole before and after the residual stress release is produced by the release of the in-plane residual stress field and the restraint of deformation in the axial direction. When the residual stress release under the plane strain condition is performed, the expansion of the cylinder is caused by the release from the stress, which is denoted by σ_z' :

$$\sigma_z' = -\nu(\sigma_x + \sigma_y), \quad (2)$$

where ν is Poisson's ratio. Thus, the diametric change caused by σ_z' is calculated as follows:

$$\frac{d - d_0}{d_0} = \frac{\nu\sigma_z'}{E} = -\frac{\nu^2}{E}(\sigma_x + \sigma_y). \quad (3)$$

The relationship between $u_r(z, \theta)$ and the residual stress field is given by the elastic solution in the following equation:

$$u_r(z, \theta) = -\frac{1}{E'}[(1 + 2 \cos 2\theta)\sigma_x + (1 - 2 \cos 2\theta)\sigma_y + 4 \sin 2\theta \sigma_{xy}] - \frac{\nu^2}{E}(\sigma_x + \sigma_y), \quad (4)$$

where $E' = E/(1 - \nu^2)$.

4. FE analysis condition

Numerical analysis is used for evaluating the effects of plastic deformation produced in the DHD processes. Figure 2 shows the object used for finite element analysis. This is the 1/4 model and

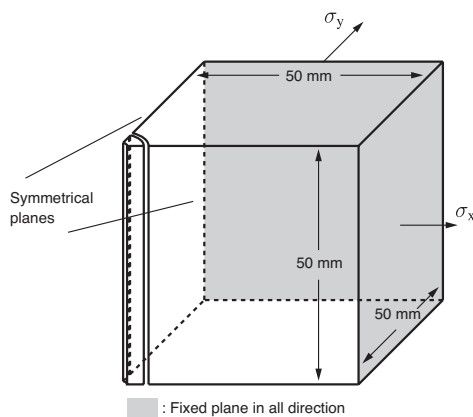

Figure 2. Object used for FE analysis.

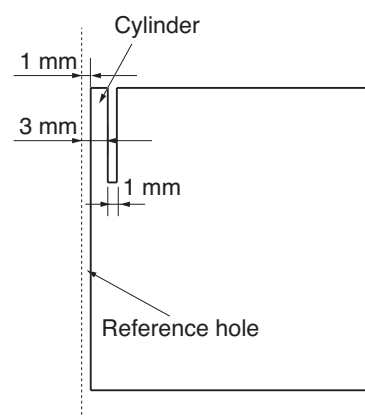

Figure 3. Sizes around the reference hole.

the size of the model is large enough not to interfere with the deformation around the reference hole. Figure 3 shows the sizes of the reference hole. The diameter of the reference hole is 2 mm. The thickness of the cylinder is 2 mm. The thickness of the trepanning is 1 mm. The sizes of the mesh in the radial direction and the through-thickness direction are approximately 0.3 mm and 0.5 mm, respectively. The arc of the reference hole is divided into 18 meshes in the θ -direction. The numerical analysis software is ABAQUS FE code Ver. 6.9. The model change option is used for removing elements. The drilling process and the trepanning process are represented by this operation. The initial residual stress fields are represented by the initial conditions option. Young's modulus, Poisson's ratio and Yield stress used for the analysis are discussed in each of following sections, because the properties change according to the purposes of the analysis.

5. Effects of plastic deformation produced in the drilling process

Stress concentration increases around the reference hole. Plastic deformation does not occur when the stress that exists before the drilling process is low. Therefore, the reference hole deforms elastically after the stress release by trepanning. In contrast, plastic deformation occurs when the stress, which exists before the drilling process, is high. When the stress is higher than one-third of the yield stress, plastic deformation occurs because the stress concentration factor around the hole is 3. When plastic deformation occurs, the trepanning process no longer produces complete stress release. Namely, the relationship between $u_r(z, \theta)$ and the residual stress field differs from that obtained by equation (4). Therefore, in this section, a quantitative evaluation method for evaluating the relationship between the residual stress field and the change in diametric change of the reference hole caused by the plastic deformation is discussed. This method makes it possible to evaluate the effects of the plastic deformation produced in the drilling process.

In the numerical analysis in this section, the material is assumed to have an elastic perfectly plastic body (E : 206 GPa, ν : 0.3, Yield stress: 500 MPa). Trepanning is performed at a time to remove the effects of the trepanning process. Figure 4 shows the relationships between $(d_x)_{\text{plastic}}$, $(d_y)_{\text{plastic}}$ and the applied stresses in the x direction under the uniaxial tensile stress state obtained by the numerical analysis, where $(d_x)_{\text{plastic}}$, $(d_y)_{\text{plastic}}$ are the values calculated by subtracting the diametric change obtained by the FE analysis from that obtained by equation (4). These values represent the effects of the plastic deformation produced in the drilling process. Here, the two factors that define these relationships are assumed as follows. The first factor is the maximum stress in the x- and y-axes around the reference hole calculated by the elastic solution. This factor represents the direction of the deformation of the reference hole and the drive force for deformation. The second factor is the von Mises equivalent stress at a position far enough away from the reference hole. This factor represents the ease of

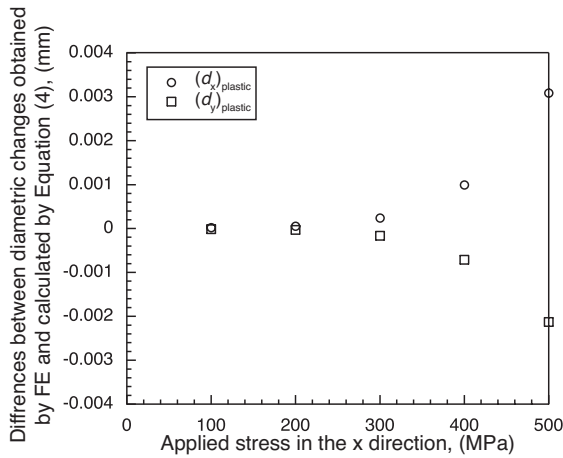

Figure 4. Differences between the diametric changes calculated by equation (4) and by FE analysis.

expanding the plastic area. Namely, $(d_x)_{plastic}$, $(d_y)_{plastic}$ are given by the unknown functions f_x, f_y as in the following equations:

$$\begin{aligned} (d_x)_{plastic} &= f_x\left(\frac{3\sigma_x}{\sigma_Y}, \frac{\bar{\sigma}}{\sigma_Y}\right) + f_y\left(\frac{-\sigma_x}{\sigma_Y}, \frac{\bar{\sigma}}{\sigma_Y}\right) \\ (d_y)_{plastic} &= f_x\left(\frac{-\sigma_x}{\sigma_Y}, \frac{\bar{\sigma}}{\sigma_Y}\right) + f_y\left(\frac{3\sigma_x}{\sigma_Y}, \frac{\bar{\sigma}}{\sigma_Y}\right), \end{aligned} \tag{5}$$

where σ_Y is Yield stress, and $\bar{\sigma}$ is von Mises stress. f_x, f_y are determined by using the results shown in Figure 4:

$$\begin{aligned} (d_x)_{plastic} &= \alpha \left(\frac{3\sigma_x}{\sigma_Y} \frac{\bar{\sigma}}{\sigma_Y}\right)^2 + \beta \left(\frac{-\sigma_x}{\sigma_Y} \frac{\bar{\sigma}}{\sigma_Y}\right)^2 \\ (d_y)_{plastic} &= \alpha \left(\frac{-\sigma_x}{\sigma_Y} \frac{\bar{\sigma}}{\sigma_Y}\right)^2 + \beta \left(\frac{3\sigma_x}{\sigma_Y} \frac{\bar{\sigma}}{\sigma_Y}\right)^2, \end{aligned} \tag{6}$$

where $\alpha = 3.61 \times 10^{-4}$, $\beta = -2.69 \times 10^{-4}$. When a biaxial stress exists, $3\sigma_x, -\sigma_x$ are substituted for $3\sigma_x - \sigma_y, 3\sigma_y - \sigma_x$. Then, it is assumed that $(d_x)_{plastic}, (d_y)_{plastic}$ satisfy equation (4) when they are regarded as $\Delta d, d_{plastic}$, which is the change in diametric change in each angles, is calculated as follows:

$$\frac{d_{plastic}}{d} = -\frac{1}{E'} \left[(1 + 2 \cos 2\theta) \sigma_x' + (1 - 2 \cos 2\theta) \sigma_y' \right] - \frac{\nu^2}{E} (\sigma_x' + \sigma_y'), \tag{7}$$

where, σ_x', σ_y' are obtained by $(d_x)_{plastic}, (d_y)_{plastic}$ and this equation. Namely, σ_x', σ_y' are functions of σ_x, σ_y . Therefore, σ_x', σ_y' are functions of in-plane stresses $\sigma_x, \sigma_y, \sigma_{xy}$ when σ_x, σ_y are regarded as the principal stresses σ_1, σ_2 . Therefore, the relationship between the in-plane residual stress field and the change in diametric change are obtained using equations (6) and (7).

6. Effects of deformation produced in the trepanning process

EDM is performed from one side to the other in the trepanning process as shown in Figure 1. In other words, the process continues to release the sectional stress. The diameter of the reference hole of the stress-unreleased area is affected by the deformation of the stress-released area, as shown in Figure 5. When plastic deformation is produced, the relationship between $u_r(z, \theta)$ and the residual stress field differs from that obtained by equation (4). Therefore, a quantitative evaluation method for evaluating the effect is discussed in this section. The effects at depth z_0 can be seen as the additional stresses $\Delta\sigma_x(z_0), \Delta\sigma_y(z_0), \Delta\sigma_{xy}(z_0)$ produced by deformation of the stress-released area. The additional stresses are applied from an area far enough from the reference hole. These additional stresses can be calculated by subtracting the actual residual stresses from the stresses $(\sigma_x)_{max}, (\sigma_y)_{max}, (\sigma_{xy})_{max}$ calculated by equation (4) and using the maximum diameter and the final diameter when the object is

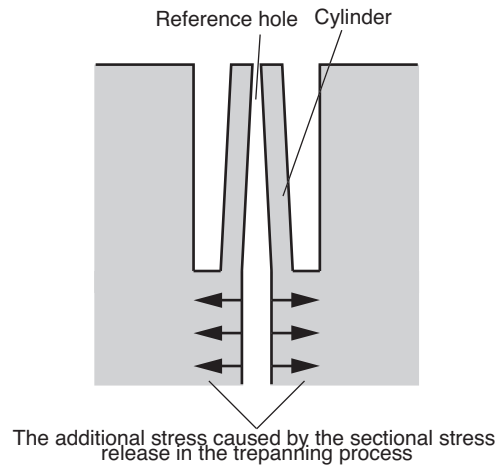

Figure 5. The additional stress caused by the sectional stress release in the trepanning process

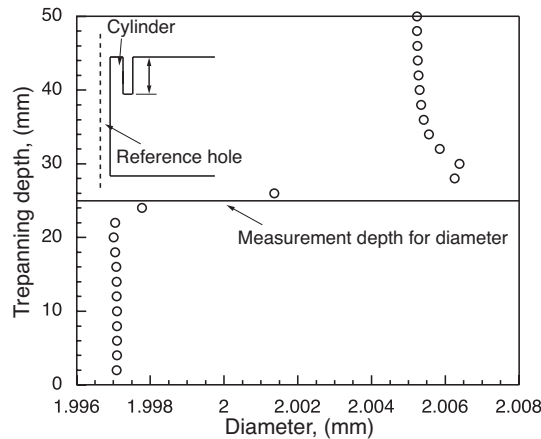

Figure 6. Relationship between diameter and trepanning depth at $z=25$ mm.

an elastic body. If the object is an elastic perfectly plastic body, $(\sigma_x)_{\max}$, $(\sigma_y)_{\max}$, $(\sigma_{xy})_{\max}$ are calculated by equations (4) and (7). Here, it is assumed that the additional stresses at depth z_0 can be determined by the in-plane stresses $(\sigma_x)_{\text{basic}}(z)$, $(\sigma_y)_{\text{basic}}(z)$, $(\sigma_{xy})_{\text{basic}}(z)$ ($0 > z > z_0$) calculated by equation (1) using the initial diameter and the final diameter. The effects of deformation of the stress released area are represented by $(\sigma_x)_{\text{basic}}$, $(\sigma_y)_{\text{basic}}$, $(\sigma_{xy})_{\text{basic}}$. Namely, $\Delta\sigma_x(z_0)$, $\Delta\sigma_y(z_0)$, $\Delta\sigma_{xy}(z_0)$ are determined by $(\sigma_x)_{\text{basic}}$, $(\sigma_y)_{\text{basic}}$, $(\sigma_{xy})_{\text{basic}}$. When the diametric changes at 0 and 90 degrees are used, $\Delta\sigma_{xy}(z_0)$, $(\sigma_{xy})_{\text{basic}}$ can be ignored. Using the unknown functions g_x , g_y , the following equation can be used to find $\Delta\sigma_x(z_0)$, $\Delta\sigma_y(z_0)$:

$$\begin{aligned}\Delta\sigma_x &= \int_0^{z_0} g_x \left((\sigma_x(z_0-l))_{\text{basic}}, (\sigma_y(z_0-l))_{\text{basic}} \right) dl \\ \Delta\sigma_y &= \int_0^{z_0} g_y \left((\sigma_x(z_0-l))_{\text{basic}}, (\sigma_y(z_0-l))_{\text{basic}} \right) dl,\end{aligned}\quad (8)$$

where l is the distance from the measurement depth. Then, $\Delta\sigma_x(z_0)$, $\Delta\sigma_y(z_0)$ are not affected by the mechanical properties of the specimens, because the stresses are an additional stress, not an additional strain. Also, $g_x((\sigma_x)_{\text{basic}}, (\sigma_y)_{\text{basic}}) = g_y((\sigma_y)_{\text{basic}}, (\sigma_x)_{\text{basic}})$ because g_x , g_y should be symmetrical. As a result, g_x , g_y can be determined under every stress state when g_x , g_y are determined under a uniaxial stress state. By numerical analysis, g_x , g_y can be determined. The material is assumed to have an elastic body (E : 206 GPa, ν : 0.3) in the numerical analysis used in this section. The trepanning process is divided into 25 steps. Figure 6 shows the diametric change in the trepanning process. In this analysis, the applied stress is 300 MPa. It is assumed that $g_x((\sigma_x)_{\text{basic}}, 0)$, $g_y(0, (\sigma_x)_{\text{basic}})$ are the products of $(\sigma_x)_{\text{basic}}$ and a function that outputs the maximum value at $l=0$ and the minimum value at $l=10$ by referring to the results. Then,

$$\begin{aligned}g_x((\sigma_x)_{\text{basic}}, 0) &= a(10-l)^2(\sigma_x(z_0-l))_{\text{basic}} \\ g_y(0, (\sigma_x)_{\text{basic}}) &= b(10-l)^2(\sigma_x(z_0-l))_{\text{basic}},\end{aligned}\quad (9)$$

where $a = -5.44 \times 10^{-4}$, $b = 1.77 \times 10^{-4}$, and

$$\begin{aligned}\Delta\sigma_x &= \int_0^{10} a(10-l)^2(\sigma_x(z_0-l))_{\text{basic}} + a(10-l)^2(\sigma_y(z_0-l))_{\text{basic}} dl \\ \Delta\sigma_y &= \int_0^{10} a(10-l)^2(\sigma_y(z_0-l))_{\text{basic}} + a(10-l)^2(\sigma_x(z_0-l))_{\text{basic}} dl.\end{aligned}\quad (10)$$

Here, when z_0-l is less than 0, $\sigma_x(z_0-l)$ and $\sigma_y(z_0-l)$ should be assumed to be zero because the area does not load the additional stress to the evaluation depth z_0 . These equations can only evaluate the additional stress effects under the biaxial stress states. When the x- and y-axes are regarded as principal axes, the additional stress effects can be evaluated under every in-plane stress state.

7. New evaluation procedure

From the results of the above discussion, the evaluation procedure in this study is performed in the following steps.

- Step 1 Calculate the stresses $(\sigma_x)_{\text{basic}}$, $(\sigma_y)_{\text{basic}}$, $(\sigma_{xy})_{\text{basic}}$ by equation (4) using the initial diameter and the final diameter.
- Step 2 Calculate $\Delta\sigma_x(z_0)$, $\Delta\sigma_y(z_0)$ using equation (10).
- Step 3 Calculate the stresses $(\sigma_x)_{\text{max}}$, $(\sigma_y)_{\text{max}}$, $(\sigma_{xy})_{\text{max}}$ using equations (4) and (7) and the maximum diameter and the final diameter.
- Step 4 Calculate the actual residual stresses by subtracting the stresses obtained in step 3 from those in step 2.

8. Suitability of the proposed procedure

The numerical analysis is used to discuss the suitability of the proposed procedure. The evaluation results are compared with that obtained by the traditional technique. In this traditional technique, the maximum diametric change is used for Δd to consider the effect of the deformation in the trepanning process. In the other words, this technique ignores the effects of the plastic deformation produced in the drilling process and considers all the deformation produced in the trepanning process as plastic deformation. This technique is called the iDHD technique and is now considered the most precise technique⁷. A material is assumed to have an elastic perfectly plastic body (E : 206 GPa, ν : 0.3, Yield stress: 500 MPa) in the numerical analysis used for this section. The trepanning process is divided into 25 steps. Applied stresses are uniform in the model. The stresses are evaluated at the through-thickness center. Naturally, the evaluation results are changed by the evaluation depth. However, the deformation state $(d-d_0)/d_0$ is nearly unchanging in area between the depth $z=10$ mm and $z=40$ mm, as shown in Figure 7. In this graph, the two deformation states are shown. One is calculated by using the initial diameter in x-axis as d_0 . The other is calculated by using the maximum diameter in the x-axis direction as d_0 . Namely, the deformation state in the DHD process is almost the same in the area between the depth $z=10$ mm and $z=40$ mm. Because the DHD technique is a technique for evaluating the inner stress fields, comparing the results at through-thickness center is enough for discussing the suitability of the proposed procedure.

Figure 8 shows the evaluation results obtained by the proposed procedure. In the graph, σ_x varies and σ_y is 200 MPa. Figure 9 shows the relationships between the evaluation results in the x' - y' system and the applied stresses along the x-axis. The x' - y' system is rotated 30 degrees clockwise from the x-y system. Each figure also shows the results obtained by the traditional technique using equation (1). In addition, Figures 10 and 11 show the errors calculated by applied stresses and evaluation results. The results indicate that the proposed procedure can evaluate the residual stress fields better than the iDHD technique at all applied stress levels even though the applied stress level is low enough that the plastic deformation does not occur. Figure 12 shows the evaluation results when the material is assumed to have an elastic perfectly plastic body (E : 206 GPa, ν : 0.3, Yield stress: 1000 MPa). Figure 13 shows the errors calculated by applied stresses and evaluation results. The results indicate that the evaluation results obtained by the proposed procedure are in good agreement with the applied stresses when the yield stress is changed.

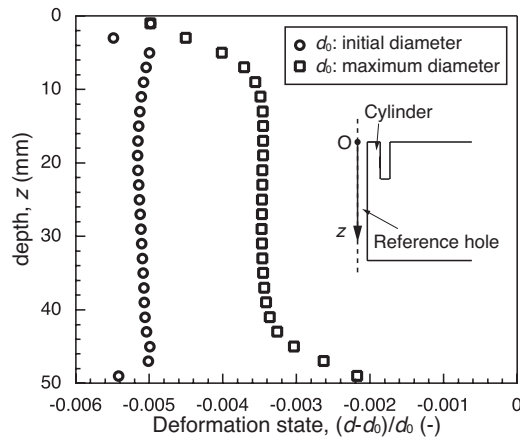

Figure 7. Relationship between deformation state $(d-d_0)/d_0$ and depth.

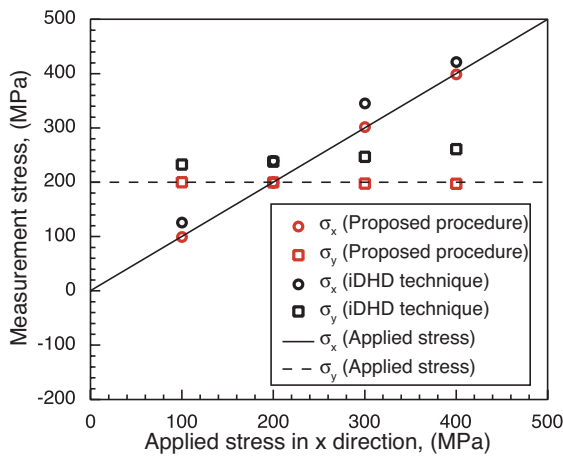

Figure 8. Evaluation results by the proposed procedure.

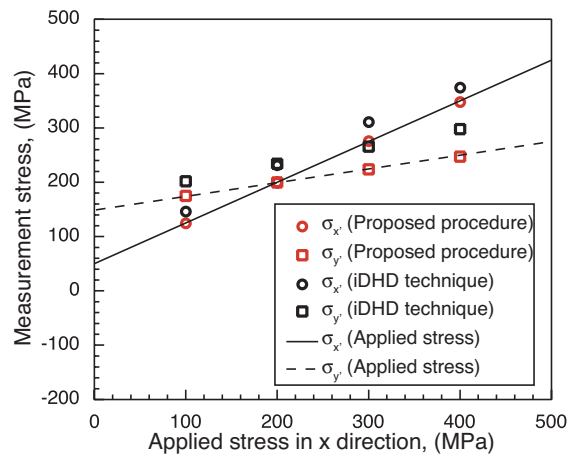

Figure 9. Evaluation results by the proposed procedure ($x'-y'$ system).

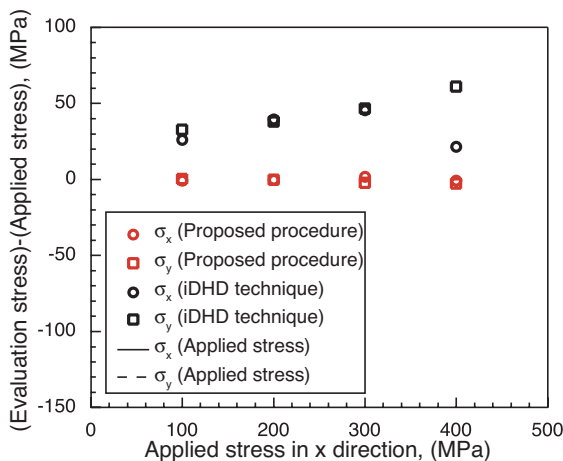

Figure 10. Evaluation errors calculated from (Evaluation stress)-(Applied stress).

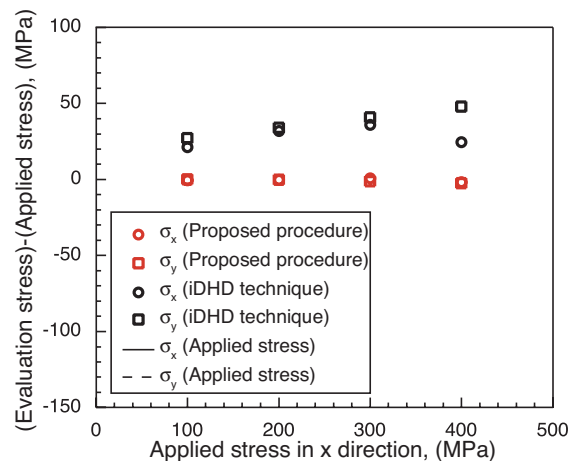

Figure 11. Evaluation errors calculated from (Evaluation stress)-(Applied stress) ($x'-y'$ system).

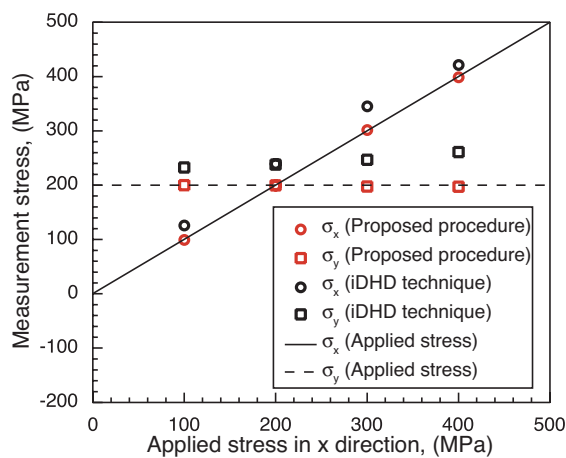

Figure 12. Evaluation results with the proposed procedure ($\sigma_y=1000$).

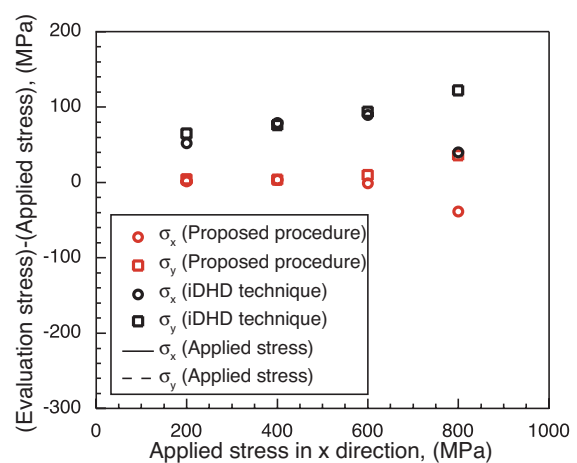

Figure 13. Evaluation errors calculated from (Evaluation stress)-(Applied stress) ($\sigma_y=1000$).

9. Conclusions

A new highly accurate evaluation procedure of internal residual stress fields by the DHD technique was proposed. In addition, the new procedure was applied to evaluate inner stress fields by FE analysis. The results indicated that the proposed procedure evaluates the residual stress fields better than the traditional DHD procedure when the measured object is thick enough that the stress condition can be assumed as the plane strain condition, such as in the model used in this study. Using the proposed procedure, the DHD technique can have wider applicability. In addition, when the procedure for considering the effects of the stress distribution in the through-thickness direction and the effect of the changes in deformation state near the surface, which is not considered in the traditional DHD procedure and the procedure proposed in this study, is proposed, the DHD technique will be able to evaluate the residual stress fields more precisely.

Acknowledgements

This study was supported by Priority Assistance for the Formation of Worldwide Renowned Centers of Research - The Global COE Program (Project: Center of Excellence for Advanced Structural and Functional Materials Design) from the Ministry of Education, Culture, Sports, Science and Technology (MEXT), Japan.

References

- [1] Ohata A, Maeda Y, Mawari T, Nishijima S and Nakamura H 1986 Fatigue strength evaluation of welded joints containing high tensile residual stresses *International Journal of Fatigue* **8** 147-50
- [2] Park M J, Yang H N, Jang D Y, Kim J S and Jin T E 2004 Residual stress measurement on welded specimen by neutron diffraction *Journal of Materials Processing Technology* **155-156** 1171-77
- [3] Leggatt R H, Smith D J, Smith S D and Faure F 1996 Development and experimental validation of the deep hole method for residual stress measurement *The Journal of Strain Analysis for Engineering Design* **31** 177-86
- [4] Bouchard P, George D, Santisteban J, Bruno G, Dutta M, Edwards L, Kingston E and Smith D 2005 Measurement of the residual stresses in a stainless steel pipe girth weld containing long and short repair *International Journal of Pressure Vessels and Piping* **82** 299-310

- [5] Brown T, Dauda T, Truman C, Smith D, Memhard D and Pfeiffer W 2006 Predictions and measurements of residual stress in repair welds in plates *International Journal of Pressure Vessels and Piping* **83** 809-18
- [6] Barber J R 2002 *Elasticity* (Dordrecht: KLUWER ACADEMIC PUBLISHERS) 87-9
- [7] Mahmoudi A H, Hossain S, Truman C E, Smith D J and Pavier M J 2009 A New Procedure to Measure Near Yield Residual Stresses Using the Deep Hole Drilling Technique *Experimental Mechanics* **49** 595-604