

OPEN ACCESS

Huddersfield University Campus Grid: QGG of OSCAR Clusters

To cite this article: Dr Violeta Holmes and Ibad Kureshi 2010 *J. Phys.: Conf. Ser.* **256** 012022

View the [article online](#) for updates and enhancements.

You may also like

- [Cathodoluminescence of tin oxide doped with europium](#)
D F Crabtree
- [Solutions in Riemannian space times of arbitrary dimension](#)
D J Booth
- [14th International Conference on Metrology and Properties of Engineering Surfaces \(Met & Props 2013\)](#)
W-E Fu



ECS
The
Electrochemical
Society
Advancing solid state &
electrochemical science & technology

DISCOVER
how sustainability
intersects with
electrochemistry & solid
state science research

Huddersfield University Campus Grid: QGG of OSCAR Clusters

Dr Violeta Holmes and Ibad Kureshi

School of Computing and Engineering, The University of Huddersfield, Queensgate, Huddersfield, UK

v.holmes@hud.ac.uk and i.kureshi@hud.ac.uk

Abstract. In the last decade Grid Computing Technology, an innovative extension of distributed computing, is becoming an enabler for computing resource sharing among the participants in “Virtual Organisations” (VO) [1]. Although there exist enormous research efforts on grid-based collaboration technologies, most of them are concentrated on large research and business institutions. In this paper we are considering the adoption of Grid Computing Technology in a VO of small to medium Further Education (FE) and Higher-Education (HE) institutions. We will concentrate on the resource sharing among the campuses of The University of Huddersfield in Yorkshire and colleges in Lancashire, UK, enabled by the Grid. Within this context, it is important to focus on standards that support resource and information sharing, toolkits and middleware solutions that would promote Grid adoption among the FE/HE institutions in the Virtual HE organisation.

1. Introduction

Grid technology has become mature enough to be deployed not only in the large research institutions, but also in small to medium HE/FE organizations.

The White Rose Grid, a consortium of Yorkshire Universities – Sheffield, Leeds and York – has demonstrated the benefits of sharing distributed resources to support research utilizing Grid computing and distributed high-performance clusters via the Internet [2]. Universities like Oxford and Cambridge have led the way in Campus Grid research [3], [4].

At the other end of the HE/research spectrum, at ELIHE Blackburn College, Lancashire, research and development work in High-Performance Computing (HPC) for teaching parallel computing theory and development of parallel applications has demonstrated that even small to medium HE institutions can deploy computer clusters using open source software and redundant hardware [5], [6].

The National Grid Service (NGS) in the UK has highlighted the need to widen Grid services and include small to medium HE and research institutions under the umbrella of NGS [7].

The University of Huddersfield, classed as a small to medium HE/FE institution, has said that it “is committed to the highest standards of Fundamental and Applied Research and has set a strategy of substantial growth in its research profile and outputs” [8]. Hence, the demand for HPC resources has increased while the funding for such resource is limited.

To respond to this need we have designed the Queensgate Campus Grid (QGG) at the University of Huddersfield, utilizing already available hardware across our schools and departments and open source solutions. We have implemented a unified resource management framework and an intelligent

resource brokering system. The University of Huddersfield is spread across 3 campuses: Huddersfield, Oldham, and Barnsley, in Yorkshire UK. The individual campus grids will be integrated into the Huddersfield University Grid.

In this paper we are reporting on our findings based on experience in deploying QGG across different departments and schools in the Huddersfield campus. Our Grid design was lead by the users' needs, in particular Mechanical Engineering and Biochemistry researchers.

2. Queensgate Grid – QGG Architecture

To unify the available resources at the University of Huddersfield into a campus grid, Queensgate campus LAN was used as the backbone and the main media for communication. The QGG architectures are heterogeneous, supporting Intel, AMD, and Sun machines, as shown in Figure 1.

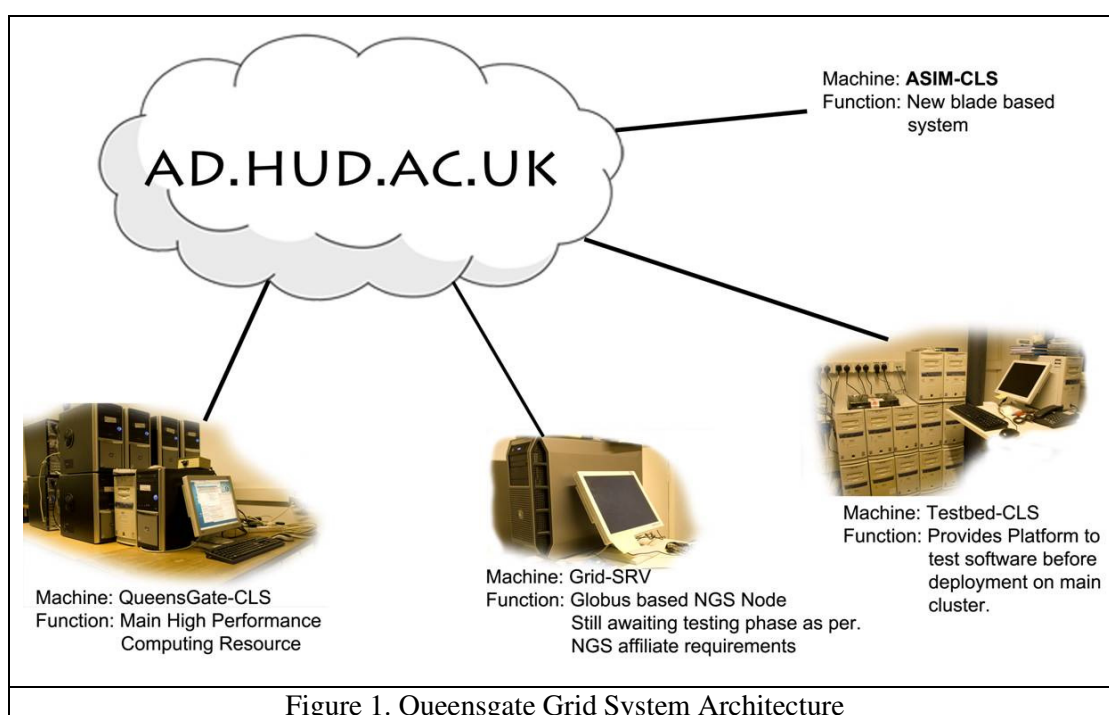

We have adopted an incremental approach in designing the university campus Grid, starting by building hardware and software system architecture for departmental/school clusters and applications. Next step involved evaluating cluster performance, speedup and efficiency by benchmarking and timing of simulations. Finally, we unified clusters and grids from various schools within the campus into the QGG.

At the heart of the QGG are three Clusters built using OSCAR cluster middleware. Two of these are shown in Figures 2 and 3.

Initially we acquired 21 Intel Core2Quad machines and used several redundant Intel and Sun machines from the School of Computing and Engineering and Applied Sciences departments to create small departmental clusters based on OSCAR middleware [9], Microsoft HPC Server 2008 R2 Beta 2 [10], and Torque [11] with the MAUI [12] scheduler. The systems currently deployed have increased in size and performance.

2.1. The Queensgate Cluster

The Queensgate Cluster was originally designed to support students and researchers in Mechanical Engineering department, running ANSYS- Fluent for computational fluid dynamics, Abaqus for finite element analysis, and DynamicStudio v3.0 for particle image velocimetry.

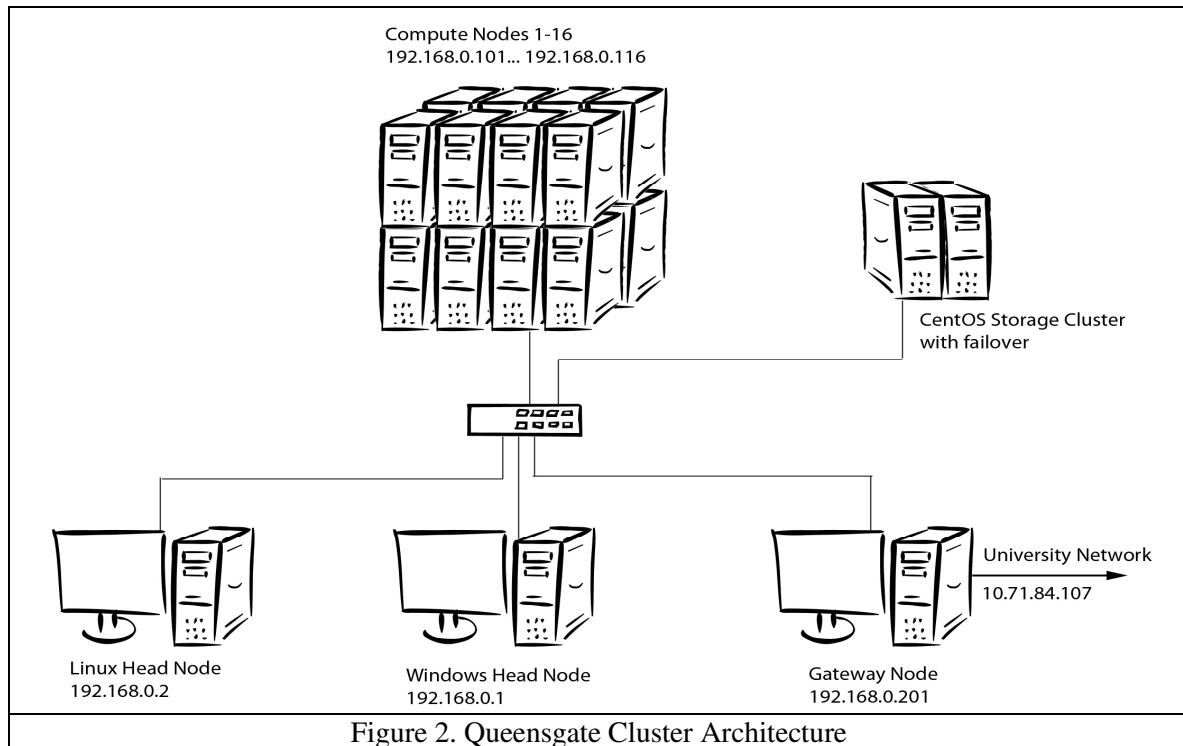

Figure 2. Queensgate Cluster Architecture

Specifications

- 64 Processing Cores
- 168GB of System Memory
- 5.2 TB of Storage
- Gigabit Interconnect
- Single Point of Entry with Failover
- Separate head nodes for each distribution
- 8 Core Storage Cluster for I/O

Software

- Linux CentOS 5.4 ker-2.6 64-bit with Oscar 5.1 b2 Middleware
- Windows Server 2008 Standard 64-bit with HPC 2008 R2 Beta 2 Middleware
- CFD Fluent 32 and 64bit upgrading to Fluent 12
- MPICH environment
- OpenMPI environment

2.2. The ASIM Cluster

The ASIM Cluster was deployed in the School of Applied Sciences, running molecular dynamics software: GAMESS, a Fortran 77 and 90 compiler, DL_POLY, AMBER, LAMMPS, NAMD, METADISE, and NWChem.

2.3. The Testbed Cluster

The Testbed Cluster is used to test different implementations of software and give users a safe environment to test their programs before deploying across the university Grid.

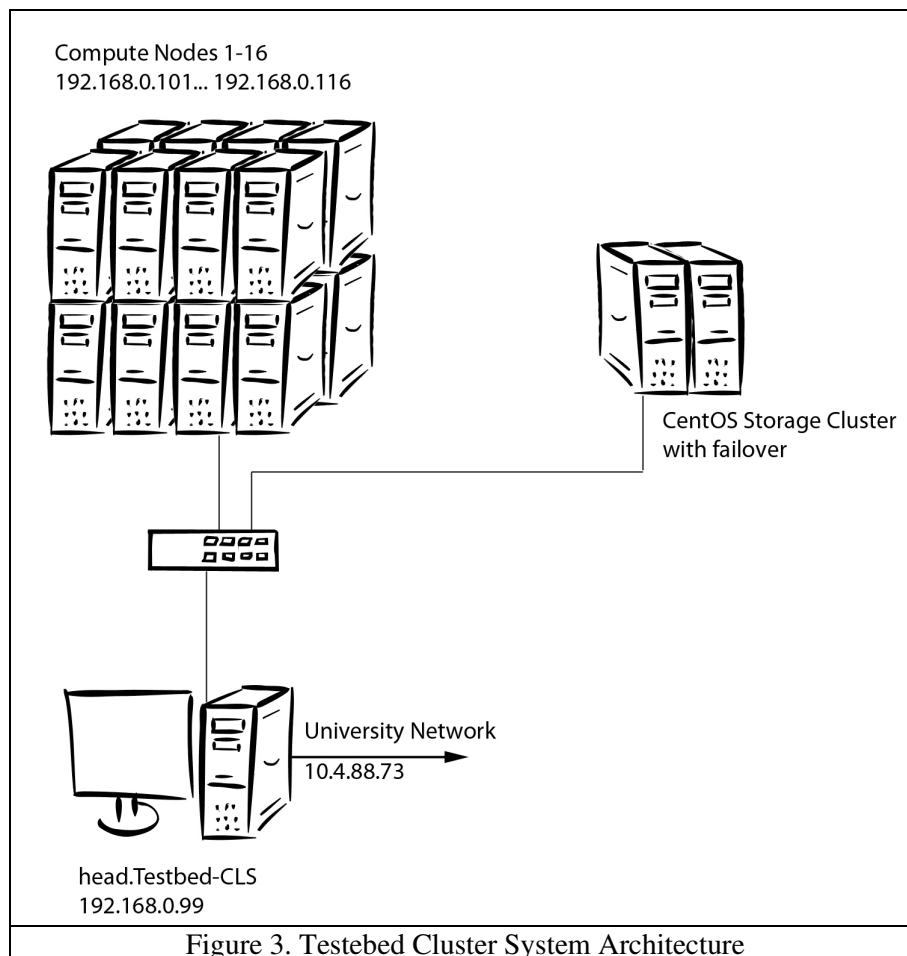

Specifications

- 16 Processing Cores
- 42GB of System Memory
- 1 TB of Storage
- Gigabit Interconnect
- Single Point of Entry
- 4 Core Storage Cluster for I/O

Software

- Linux CentOS 5.4 ker-2.6 32-bit with Oscar 5.1 b2 Middleware
- MPICH environment
- OpenMPI environment

These clusters currently run fluid dynamics simulations [13], molecular dynamics simulations, various computation algorithms, and rendering for video and image processing. Figures 4-9 depict the results of certain simulations.

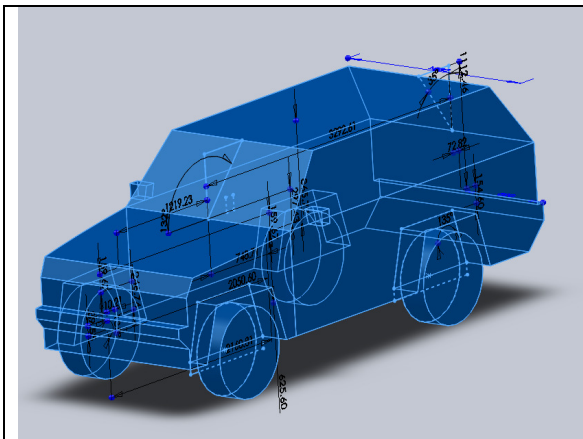

Figure 4. Student Project on Performance of a Range Rover

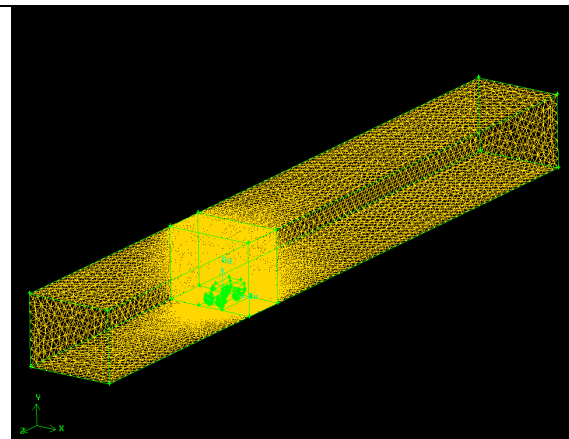

Figure 5. Mesh used for Range Rover CFD Analysis

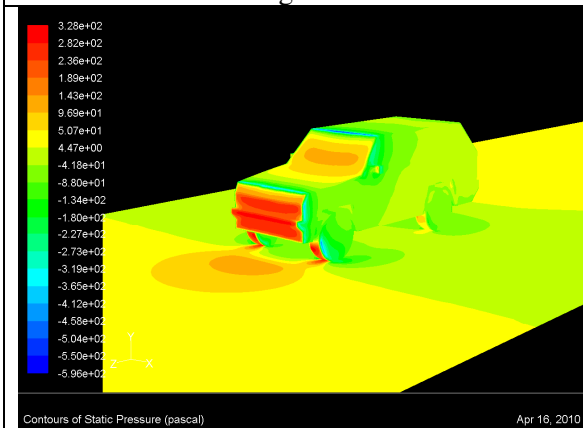

Figure 6. Image of Static Pressure Contours after Simulation

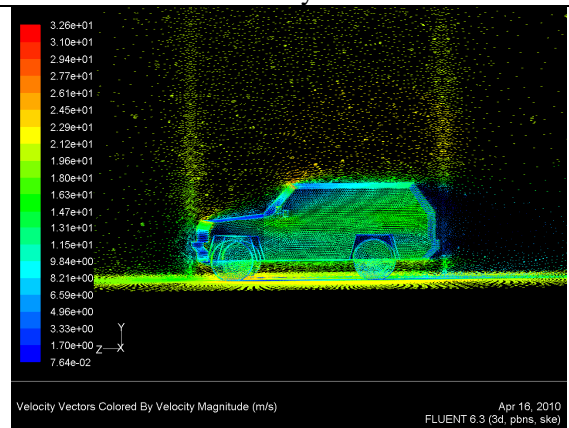

Figure 7. Air Flow Velocity Vector Diagram after Simulation

Grid Size

Level	Cells	Faces	Nodes	Partitions
0	7048243	14449495	1358115	8

```

Performance Timer for 7000 iterations on 8 compute nodes
Average wall-clock time per iteration:      31.046 sec
Global reductions per iteration:           146 ops
Global reductions time per iteration:      0.000 sec (0.0%)
Message count per iteration:               745 messages
Data transfer per iteration:               47.325 MB
LE solves per iteration:                   6 solves
LE wall-clock time per iteration:          7.432 sec (23.9%)
LE global solves per iteration:            2 solves
LE global wall-clock time per iteration:   0.106 sec (0.3%)
AMG cycles per iteration:                 8 cycles
Relaxation sweeps per iteration:          391 sweeps
Relaxation exchanges per iteration:        68 exchanges

Total wall-clock time:                     217322.798 sec
Total CPU time:                            1571160.240 sec
    
```

Figure 8. Fluent CFD information of Dataset and Simulation CPU Time of 18d-4hr-26min completed in 2d-12hr-22min, 7.2 times faster using eight nodes instead of one

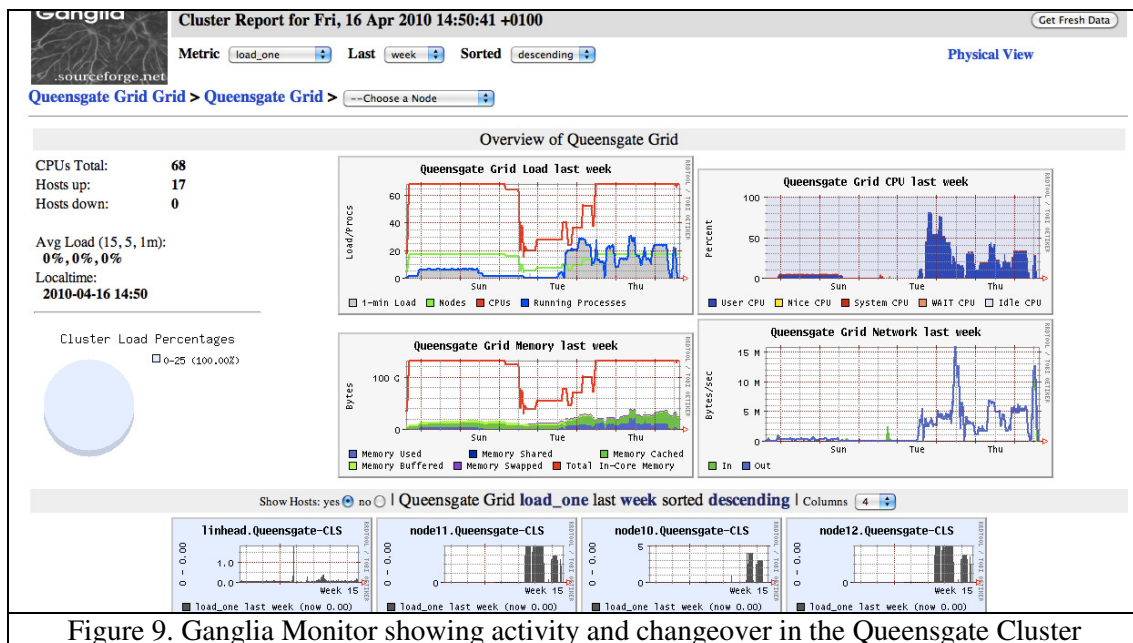

Figure 9. Ganglia Monitor showing activity and changeover in the Queensgate Cluster

2.4. The Clusters' performance evaluation

The Clusters were tested extensively to determine their performance, speed up, efficiency, and power consumption. The benchmarking was done on the basis of LINPACK using ATLAS libraries and is summarized in table 1.

Table 1. Clusters benchmarking with LINPACK

Cluster	Number of Cores	GFlops (max)	Efficiency	Current Max	Power Max	Power/GFlop
Testbed	16	1.5	~4%	7A	1.6KW	~1KW
Asim	14	28	76%	8A	1.6KW	60W
Queensgate	64	120	84%	13A	2.4KW	20W

The efficiency of the 2.4GHz P4 machines in Testbed cluster is only 4%, compared to 76% and 84% for Asim (2.3GHz AMD machines) and Queensgate (2.33GHz Cre2Quad machines) clusters respectively. It is clear that the computational power factor has changed due to Hyperthreaded and On-Board/On-chip parallelism.

3. QGG Deployment

In order to support grid requirements, there are a number of functions that needed to be provided across the VO – IT resources, servers, storage, and network. Grid administration was required for maximum utilization of the resources and System Integrators to reduce the complexity of the distributed and heterogeneous systems.

In the process of deploying the QGG various innovative solutions were devised.

From the HW/SW appraisal it was evident that a cluster based on Linux systems would not adequately cover the university requirements. Several software packages ran only on the Windows platform (e.g. 3d Studio Max for image rendering, Dynamic Studio v3.0 for particle velocimetry), while others had licenses which were platform locked to Windows (e.g. 3dsMAX). As this project aimed to establish the need of HPC at the University using existing hardware and open-source software, it was neither feasible nor possible to make two Clusters which would run the two platforms.

The solution to this was to implement a hybrid Linux-Windows HPC Cluster that seamlessly and automatically accepts and schedules jobs in both domains and provides dynamic changeover between the two operating systems, based on the jobs' requirements. This was achieved through autonomous agent software and scripts [17].

To support users who prefer to use a graphical user interface rather than a command line input, a Fluent portal was designed and implemented, as seen in Figure 10. The portal provides a web based workflow that allows users to upload their design files (made on their desktop computers), set the FLUENT CFD parameters for the simulation through a GUI interface (created with PHP). The FLUENT specification file is generated in the FLUENT Scheme Language. The user can specify the computational requirement of the jobs. A job file is created using BASH and the PBS JDL, and finally uploaded to the Grid to execute.

Submit your job to the cluster
[Home](#)

Create a new Journal file :

Which type of flavour ?
 2D / 2DDP 3D / 3DDP

START-UP
Scale/Grid :

SOLVER SETTINGS
Solver : Time : Gradient Option :
Velocity Formulation :

VISCOS MODEL SETTINGS
Model : k-epsilon k-omega

THERMAL ANALYSIS
Use Energy Equation ?
 Yes No

MATERIALS
Fluid
Material : Air Water
Properties :
Density : kg/m³
Viscosity : kg/m-s
Solid
Material : Aluminium
Properties :
Density : kg/m³

OPERATING CONDITIONS
Pressure :

Figure 10. A portal for non-command-line based Fluent users

Currently we are investigating the unification of the computing resources in the University. There are number of possible solutions:

- Condor – to enable the utilization of 5000 PCs that are idle for 60% of the time, especially during the holiday periods
- Globus – a de-facto standard for Grid in the UK, and will enable us to share our resources with the National Grid Service (NGS) community.
- G-Lite – as part of a Grid-Enabled HPC project evaluating a Cloud support for UK e-Science community
- NGS VDT which is based on Globus with GRAM, GSISSH, MyProxy, and is the Grid middleware of choice in the NGS.

4. Summary and Future work

In the short term, we have made the QGG a 'cluster of clusters'. The system provides a single point of entry to grid technology [14] [15] for the University's student, staff and research community. Some enterprise work has also been undertaken; QGG provides the precision in simulations required by industry.

We have successfully deployed multiple Clusters using heterogeneous hardware and software, linked via University intranet, and defined the architecture based on the requirements of researchers and students. We have also evaluated a variety of open-source software and hardware platforms and established their suitability for meeting the educational and research needs of students and staff within the Higher Education institutions. Our findings are summarized in Table 2, with CentOS 5.4 being the preferred Linux Operating System.

Table 2. Linux OS choice

Support	Fedora Core 5	Fedora Core 9	Ubuntu 8.10	OpenSUSE 10.1	CentOS 5.4
New Hardware			√		√
OSCAR 5	√				
OSCAR 5.1 (rc1/b1)		√		√	√
OSCAR 6.0		√	√		√
Long Term			√		√
Application			√	√	√
Ease of Installation	√	√	√	√	√
Usability straight out of the Box		√			√
Non-technical User Friendly			√		

A plethora of software has been deployed to meet the needs of our researchers and students.

With over 18000 jobs being completed on the QGG clusters realistic feedback could be gained from the existing users to judge whether the system is effective.

Interviewing the researchers from the Department of Mechanical Engineering has revealed that within the first 2 months of the resource being available, the users changed their project deliverables and started to attempt more complex problems and simulations. The explanation for this change is that the HPC facility has enabled users to increase the quality of their research output.

The Department of Chemistry and Biological Sciences immediately saw the benefits of an HPC system; they already had small HPC clusters and had an access to NGS. However, the staff and researchers immediately felt the benefits of a centralised HPC resource and a Grid connecting the various resources. It made connectivity and usability much easier. Having one point of contact for technical support, resource accessibility and NGS connectivity, simplified the workflow for researchers so they can concentrate on their work instead on problems such as a node in a cluster not being responsive.

Infrastructure wise, software licenses were limiting many users and therefore the full potential of the QGG clusters could not be experienced. The end-to-end latency and interconnects bandwidth also became a bottleneck for an embarrassingly parallel programs as it would not scale well as nodes were increased. For this application users were connecting to the NGS where high-speed Infiniband interconnects are available. Out of the pool of applications deployed on the Queensgate Cluster and the QGG this was the only exception so far, were a decrease in performance was felt on scaling.

In conclusion, we have achieved our main objective, which was to provide a framework for future expansion of HPC resources at the University.

Our future research efforts will be directed towards a Grid/Cloud infrastructure combining available resources from University schools and departments, and from neighbouring FE colleges. We intend to link the geographically-dispersed campuses in Yorkshire and the University Centre at Blackburn College, Lancashire [16]. This will lead to establishing a Virtual Organization comprising a consortium of small to medium colleges and HE institutions in Lancashire and Yorkshire, UK. It will enable resource sharing such as cluster storage, processing power, instrumentation, dedicated software

and hardware, and encourage collaboration between our institutions, establishing a framework for Cloud infrastructure for education, industry, business and local government.

References

- [1] Foster, Ian, and Carl Kesselman., "The Grid 2: Blueprint for a New Computing Infrastructure" San Francisco, Calif.: Morgan Kaufmann, 2004. Print.
- [2] Dew, P. M., Schmidt, J. G., Thompson M and Morris, P., "The White Rose Grid: practice and experience"
- [3] Wallom David C. H., Trefethen Anna E., "OxGrid, a campus grid for the University of Oxford" Proceedings of All Hands Meeting 2006
- [4] Calleja M., B. Beckles, M. Keegan, M. A. Hayes, A. Parker and M. T. Dove, "CamGrid: Experiences in constructing a university-wide, Condor-based, grid at the University of Cambridge"
- [5] Holmes, V and McDonough, T., "The ELIHE High-Performance Clusters for Parallel Computing", Proceedings of IPSI conference IPSI -2006 Marbella, Spain.
- [6] Holmes, V. and McDonough, T., "The ELIHE High-Performance Cluster, Proceedings of Cluster 2005 conference (Poster)", Boston, USA.
- [7] *NGS | Connecting Infrastructure, Connecting Research*. Web. 16 Apr. 2010. <<http://www.ngs.ac.uk/>>.
- [8] "Research Home." *Research*. University of Huddersfield. Web. 16 Apr. 2010. <<http://www2.hud.ac.uk/research/research/>>.
- [9] *OSCAR Project*. Open Cluster Group. Web. 16 Apr. 2010. <<http://oscar.openclustergroup.org/>>.
- [10] "Windows HPC Server 2008 | Microsoft Supercomputing | Supercomputers." *Microsoft Corporation*. Web. 16 Apr. 2010. <<http://www.microsoft.com/HPC/>>.
- [11] "Torque Scheduler." *Cluster Resources*. Web. 16 Apr. 2010. <<http://www.clusterresources.com/>>.
- [12] "MOAB" *Cluster Resources*. Web. 16 Apr. 2010. <<http://www.clusterresources.com/>>.
- [13] "Fluent CFD." *ANSYS UK*. Web. 16 Apr. 2010. <<http://www.fluent.co.uk/>>.
- [14] "Globus Toolkit." *The Globus Alliance*. Web. 16 Apr. 2010. <<http://www.globus.org/>>.
- [15] "Condor Project Homepage." *UW-Madison Computer Sciences Department Home Page*. Web. 16 Apr. 2010. <<http://www.cs.wisc.edu/condor/>>.
- [16] *Blackburn College Website | Blackburn College Home Page*. Web. 16 Apr. 2010. <<http://www.blackburn.ac.uk/>>.
- [17] Kureshi, I., Holmes, V. and Liang, S., "Hybrid HPC – Establishing a Bi-Stable Dual Boot Cluster for Linux with OSCAR middleware and Windows HPC 2008 R2", Proceedings of All Hands Meeting 2010, Cardiff, UK.