

OPEN ACCESS

A new rechargeable intelligent vehicle detection sensor

To cite this article: L Lin *et al* 2005 *J. Phys.: Conf. Ser.* **13** 102

View the [article online](#) for updates and enhancements.

You may also like

- [Traffic vehicle cognition in severe weather based on radar and infrared thermal camera fusion](#)
Wang Zhangu, Zhan Jun, Duan Chuanguang et al.
- [Influence of the Anode and the Accelerator on Copper Bath Aging in the Damascene Process](#)
P. Moçotéguy, C. Gabrielli, H. Perrot et al.
- [Low-frequency Inductive Loop and Its Origin in the Impedance Spectrum of a Graphite Anode](#)
Arun Thapa and Hongwei Gao



ECS
The
Electrochemical
Society
Advancing solid state &
electrochemical science & technology

DISCOVER
how sustainability
intersects with
electrochemistry & solid
state science research

A New Rechargeable Intelligent Vehicle Detection Sensor

L Lin¹, X B Han¹, R Ding², G Li¹, Steven C-Y Lu¹, Q Hong¹

¹ Inspiring Technology Research Laboratory, Tianjin University, Tianjin, 300072
CHINA

² Tianjin University of Technology and Education, Tianjin 300222, CHINA

E-mail: linling815@vip.sina.com

Abstract. Intelligent Transportation System (ITS) is a valid approach to solve the increasing transportation issue in cities. Vehicle detection is one of the key technologies in ITS. The ITS collects and processes traffic data (vehicle flow, vehicular speed, vehicle density and occupancy ratios) from vehicle detection sensors buried under the road or installed along the road. Inductive loop detector as one type of the vehicle detector is applied extensively, with the characters of stability, high value to cost ratio and feasibility. On the other hand, most of the existing inductive loop vehicle detection sensors have some weak points such as friability of detective loop, huge engineering for setting and traffic interruption during installing the sensor. The design and reality of a new rechargeable intelligent vehicle detection sensor is presented in this paper against these weak points existing now. The sensor consists of the inductive loop detector, the rechargeable batteries, the MCU (microcontroller) and the transmitter. In order to reduce the installing project amount, make the loop durable and easily maintained, the volume of the detective loop is reduced as much as we can. Communication in RF (radio frequency) brings on the advantages of getting rid of the feeder cable completely and reducing the installing project amount enormously. For saving the cable installation, the sensor is supplied by the rechargeable batteries. The purpose of the intelligent management of the energy and transmitter by means of MCU is to minimize the power consumption and prolong the working period of the sensor. In a word, the new sensor is more feasible with smaller volume, wireless communication, rechargeable batteries, low power consumption, low cost, high detector precision and easy maintenance and installation.

1. Introduce

The increasing transportation issue in cities and in the highways that directly influences the development of economy and the life of residents has being prevalent all over the world. Intelligent Transportation System (ITS) is a valid approach to solve this issue. Vehicle detection is one of the key technologies in ITS. The ITS collects and processes traffic data (vehicle flow, vehicular speed, vehicle density and occupancy ratios) from vehicle detection sensors buried under the road or installed along the road. Detailed and sufficient traffic data is the basis of the intelligent transportation. There are various kinds of Vehicle detection sensors, for example the inductive loop detector, magnetic detector, pulse ultrasonic detector, radar detector, photoelectric detector, and video detector etc. The magnetic detector can only detect the passed vehicles and can't detect the static vehicles. The low detecting precision and the weak anti-jamming capability are the disadvantages of the pulse ultrasonic detector, the radar detector and the photoelectric detector [1]. The video detector has the disadvantages of the high cost, the poor real time performance and the detecting precision is influenced by the level of the

hardware and the software [2]. With the characteristics of stability, high value to cost ratio and feasibility, the inductive loop detector is applied extensively. Nevertheless, most of the existing inductive loop vehicle detection sensors have some weak points. The inductive loop (2m*1.5m generally) buried in the road transforms the signals to the vehicle detector by feeder cable [3]. The large volume of the inductive loop and needing feeder cable bring on huge engineering for setting, traffic interruption during installing the sensor. Furthermore the inductive loop is so large that it is easily damaged and hard to repair. Therefore, its applications are limited and its working period is shortened.

J.F. Scarzello proposed a kind of magnetic detector communicated in RF in the late 70s of the last century [4]. Communication in RF benefits to saving the feeder cable completely. So the design and reality of a new rechargeable intelligent inductive loop vehicle detection sensor communicated in RF is presented in this paper. The new sensor is more feasible with smaller volume, wireless communication, rechargeable batteries, low power consumption, low cost, high detector precision and easy maintenance and installation. So it can not only be used in detecting vehicles in the traffic lane, but also apply in parking automation system.

2. System Structure

The block diagram of the new rechargeable intelligent vehicle detector presented in this paper is improved on the base of the magnetic detector proposed by J.F Scarzello, as is shown in figure 1. In order to reduce the power consumption and the cost of installing and repairing, the volume of the detector is dwindled as much as possible and the MCU which manages the transmitter and the power module is added in the design.

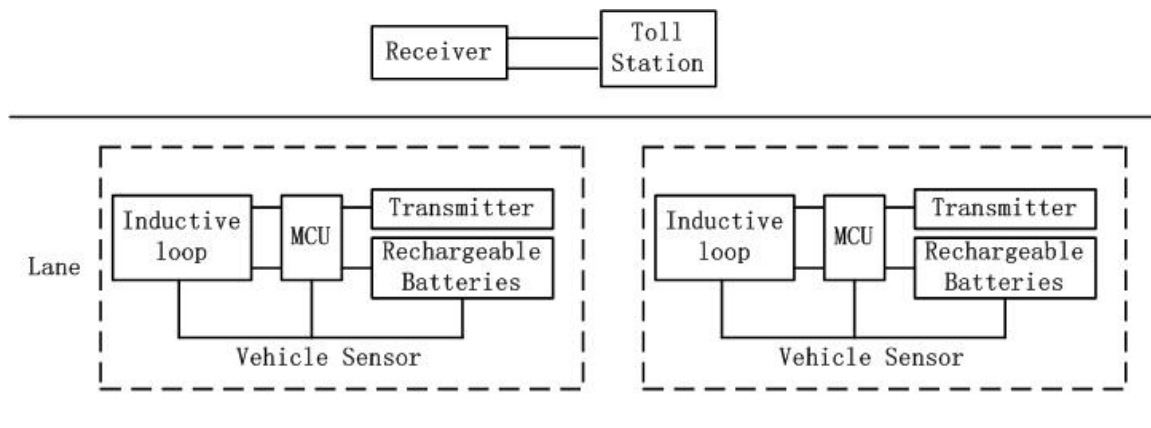

Figure 1. The block diagram of the rechargeable intelligent vehicle detector

The rechargeable intelligent vehicle sensor, which contains the detector module, the power module, the control module and the transmitter module is shown in figure 2.

The detector module is an oscillator that consists of a detector loop and an inverter. The purpose of reducing the volume of the inductive loop with a ferrite bar is to make the loop durable, enhance the stability of the oscillating frequency and the detecting precision and sensitivity.

The control module is a low consumed power intelligentized MCU. The rPIC12F675 is chosen as the control module and has the advantages of RISC (Reduced Instruction Set Computing), low cost, low power consumption, integrated transmitter etc. The purpose of the intelligent management of the power and the transmitter by means of MCU is to minimize the power consumption and prolong the working period of the sensor. When the vehicles passed or halted above the loop, the vehicles induce the change of the oscillating frequency. The detectors can detect the passing or existence of the vehicles by measuring the change of the oscillating frequency. If the changed value of the oscillating frequency is larger than the threshold value, the transmitter sends out the signal which represents the passing or existence of the vehicles by an antenna. The transmitter only radiates one shot of signal when

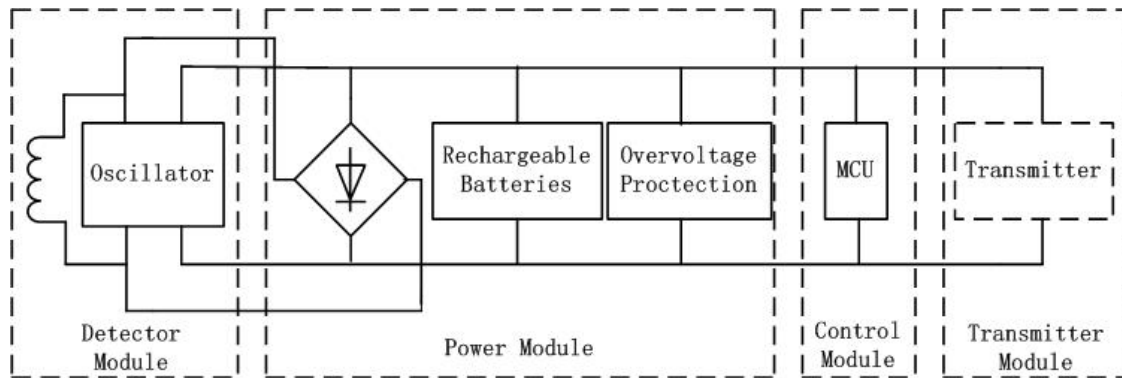

Figure 2.The Rechargeable Intelligent Vehicle Sensor

only a vehicle passed the detector and the MCU should operate in the power-down mode when the MCU doesn't detect the frequency during the passing of the vehicles, so as to save the power and avoid when a vehicle stays on the detector for a long time, the transmitter radiates redundant signals to consume the golden energy. To save the setting of feeder cable completely and reduce the installing project amount effectively, the detector communicates with outside circuits in RF.

The batteries selected for the sensor are three 1.2V 1600mAh Ni-MH rechargeable batteries. The power module is managed by the MCU. When the power module is in the brown-out conditions, the transmitter sends out the signal which represents the batteries need to charge. During the charging stage, the inductive loop takes as charging loop and the batteries are charged by the electromagnetic energy in high frequency passing the commutating bridge. When the voltage of the batteries exceeds the threshold voltage, the batteries are protected by the overvoltage protection and the transmitter sends out the signal which stands for preventing charging.

The battery charger is shown in figure 3, by which the batteries of the vehicle sensor can be charged

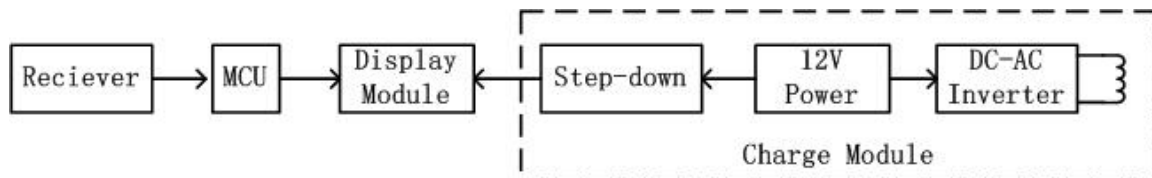

Figure 3.Battery Charger

with the help of the staff in a non-contact-type way. In this way, the power supply cable is saved, and the projected amount of installation is reduced. The charger is formed by the receiver module, MCU, the display module and the charge module. The charge module is composed of the power supply, the high frequency dc-to-ac inverter and the power storage inductive loop. The power adopts 12V electrical level which is used in the vehicle. The DC voltage is charged to the high frequency AC voltage by the high frequency dc-to-ac inverter. Then, under the help of the coupling between the power storage inductive loop and the sensor's inductive loop, the rechargeable batteries are charged. During the process of charging, the MCU samples the voltage of the batteries, and emits it through the transmitter. The signal is received by the receiver. At the same time, under the control of the MCU, the charging stage is shown by the display module. So the staff can see the charging stage in vision. When the batteries are full, a signal is emitted by the sensor and received by the charger. Then, a light-sound signal is alarms to remind the staff stop charging.

In summary, in order to get rid of the feeder cable completely and reduce the installing project amount enormously, communication in RF, the rechargeable batteries and the batteries charged in the non-contact-type way are adopted. The purpose of the intelligent management of the power and transmitter by means of MCU is to minimize the power consumption, prolong the working period of the sensor and reduce the cost of maintenance. So the low power consumption is very important to the sensor. The power consumption of the sensor will be calculated as follow.

3. Calculation of Power Consumption

MCU can detect the passing or existence of the vehicles by measuring the change of the oscillating frequency. For saving the power, the MCU should operate in the sleep mode when the MCU doesn't detect the frequency during the passing of the vehicles, Where T_w is the sleeping time. When the sleeping time is out, MCU is woken up by the Watchdog Timer and the TIMR0 and the TIMR1 are started. The TIMR0 uses the external oscillator as a clock source and the TIMR1 is incremented on the edge of the MCU system clock. When the TIMR0 rolls over, MCU can read the TIMR1 register in the Interrupt Service Routine. MCU can decide whether the vehicles have passed or not by the change of the TIMR1 register.

As is shown in figure 4, the capacitance connecting three point type oscillator consists of the inductive loop L, the inverter U1, C₁ and C₂. The oscillating frequency can be represented as:

$$f = 1/2\pi\sqrt{LC_1C_2/(C_1 + C_2)} \quad (1)$$

where L=79mH, C₁=C₂=0.01μF, then f=8kHz. The TMR0 uses the output of the oscillator shaped by U2 as a clock source inputted by the T0CKI pin. The SN74AUP1G14 is chosen for the inverter U1 and U2, while I_{DD} is the maximum static current of the inverter.

The dynamic incurrent can be represent as:

$$I_C = C_L V_{DD} f \quad (2)$$

where C_L is the load capacitor at the output of the inverter, V_{DD} which equals 3V is the operating voltage of the inverter, f which equals 8kHz is the operating frequency of the inverter. To U1, while C_{L1} which is the load capacitor equals 0.01 μF, Substitute C_{L1} , V_{DD} and f into equation (2), then I_{C1} which is the dynamic incurrent equals 240μA. To U2, while C_{L2} which is the load capacitor equals 5pF, Substitute C_{L2} , V_{DD} and f into equation (2), then I_{C2} which is the dynamic incurrent equals 0.12 μA. The total incurrent consumed by U1 and U2 can be represented as:

$$I_1 = 2I_{DD} + I_{C1} + I_{C2} = 241.92\mu A \quad (3)$$

Suppose L as the vehicle length equals 3m, V_c as the speed when the vehicles pass the crossing in the city equals 50km/h, V_h as the speed when the vehicles pass the crossing in the expressway equals 120km/h. The time which the vehicles passed the sensor can be represented as:

$$\text{In the city: } t_{pc} = L/V_c = 216\text{ms} \quad \text{In the expressway: } t_{ph} = L/V_h = 90\text{ms}$$

The changing amount of the oscillating frequency Δf which we got in the experiment equals 1Hz. So the changed oscillating frequency $f' = 8.001\text{kHz}$. The TIMR0 is incremented on the edge of the square wave outputted by U2. In order to recognize the changing amount of the external clock, N should write into the TIMR0 register. However, $f_{osc} = 4\text{MHz}$ as the internal clock used by MCU, and the clock used by the TMR1 $f_{TMR0} = 1\text{MHz}$. While the external frequency is f , the value in the TMR1 register $n_1 = Nf_{TMR0}/f$. While the external frequency is f' , the value in the TMR1 register $n_2 = Nf_{TMR0}/f'$. The difference of the count:

$$\Delta n = |n_1 - n_2| = Nf_{TMR0}\Delta f / ff' \quad (4)$$

When it is lager than or equal to 2, the changing amount of the oscillating frequency could be recognized. Suppose $\Delta n = 4$, Substitute f_{TMR0} , Δf , f , f' and Δn into equation (4), then we can get $N = 256$. The time needed in each detecting process $t_s = N/f = 32\text{ms}$.

When the vehicles pass the sensor, the transmitter started to send out the signals. The maximum transmitter ready time $t_{r1} = 1.5\text{ms}$, the maximum transmitter current $I_r = 20\text{mA}$, and the maximum data ratio equals 40kbps. The time needed in the process of transmitting 8 bits $t_{r2} = 8/40000 = 0.2\text{ms}$. So the time needed in emitting a 8 bit signal by transmitter $t_r = t_{r1} + t_{r2} = 1.7\text{ms}$.

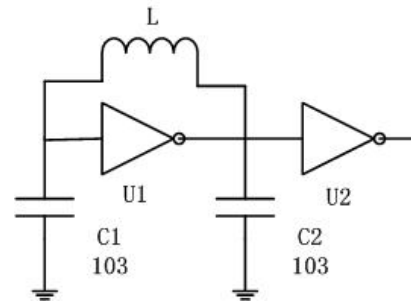

Figure 4. Oscillator

In order to ensure the MCU stays in the sleep mode as long as possible and the oscillating frequency can be detected when the vehicles pass every time. As is shown in figure 5, The maximum sleeping time:

$$T_w = T - 2T_s \quad (5)$$

where T is the time which the vehicles passed the sensor, T_s is the sum of the detecting time and transmitting time. So $T_s = t_s + t_r = 33.7\text{ms}$. Substitute T and T_s into equation (5).

In the city: $T_w = 148.6\text{ms}$

In the expressway: $T_w = 22.6\text{ms}$

While the maximum current consumed by rPIC12F675 in the sleep mode $I_w = 3.5 \mu\text{A}$, the maximum operating current consumed by rPIC12F675 in the INTOSC mode $I_i = 500 \mu\text{A}$, The average of the current consume by rPIC12F675 $I_2 = (I_w T_w + I_i T_s + I_i t_r) / (T_w + T_s)$.

In the city: $I_{C2} = 276.63 \mu\text{A}$

In the expressway: $I_{h2} = 904.6 \mu\text{A}$

The total current consumed by the sensor $I_3 = I_1 + I_2$.

In the city: $I_{C3} = 518.55 \mu\text{A}$

In the expressway: $I_{h3} = 1.147\text{mA}$

The batteries selected for the sensor is three 1.2V 1600mAh Ni-MH rechargeable batteries. So the continuing operating time $T_D = 1600 \times 10^3 / I_3$.

In the city: $T_{CD} = 128$ days

In the expressway: $T_{HD} = 58$ days

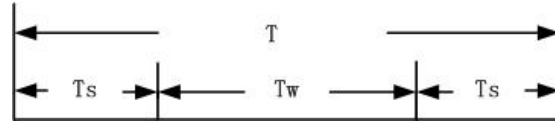

Figure 5. Calculation of the Sleeping Time

4. Conclusion

The design and reality of a new rechargeable intelligent inductive loop vehicle detection sensor is presented in this paper. The new sensor is more feasible with smaller volume, wireless communication, rechargeable batteries, low power consumption, low cost, high detector precision and easy maintenance and installation. The sensor can exactly provide a lot of important traffic data such as vehicle flow, vehicular speed, vehicle density and occupancy ratios for ITS. So it can not only use in detecting vehicle in the traffic lane, but also apply in parking automation system.

Acknowledgements

This paper is supported by the Tianjin college development foundation of scientific and technological, China. (No. 20041314)

Reference

- [1] Dalgleish M J Vehicle Detection for Advanced Transport Telematics *Golden River Traffic Ltd UK* 164-167
- [2] Jiang Z F and Tan G L 1996 The Development of The Vehicle Detector *J.Highway Transportation Research and Development (in Chinese)* 13 62-65
- [3] Sun G D, Jiang Y L and Qi Q 2003 The Design and Realization of Intellectual Loop-coil Detector in Traffic *J.Control & Automation (in Chinese)* 19 54-57
- [4] Scarzello J F, Lenko D S, Brown R E and Krall A D 1978 SPVD: A Magnetic Vehicle Detection System Using A Low Power Magnetometer *J.IEEE TRANSACTIONS ON MAGNETICS, SEPTEMBER. MAG-14* 574-576