

Certainty relations between local and nonlocal observables

This article has been downloaded from IOPscience. Please scroll down to see the full text article.

2005 New J. Phys. 7 256

(<http://iopscience.iop.org/1367-2630/7/1/256>)

View [the table of contents for this issue](#), or go to the [journal homepage](#) for more

Download details:

IP Address: 38.107.179.210

The article was downloaded on 20/02/2012 at 22:17

Please note that [terms and conditions apply](#).

Certainty relations between local and nonlocal observables

R Garcia Diaz¹, J L Romero¹, G Björk¹ and M Bourennane²

¹ School of Information and Communication Technology, Royal Institute of Technology (KTH), Electrum 229, SE-164 40 Kista, Sweden

² Fysikum, Stockholm University, SE-106 91 Stockholm, Sweden

E-mail: gunnarb@imit.kth.se

New Journal of Physics 7 (2005) 256

Received 19 August 2005

Published 29 December 2005

Online at <http://www.njp.org/>

doi:10.1088/1367-2630/7/1/256

Abstract. We point out that for an arbitrary number of identical particles, each defined on a Hilbert space of arbitrary dimension, there exists a whole ladder of relations of complementarity between certain local and nonlocal measurements corresponding to every conceivable grouping of the particles, e.g., the more accurately we can know (by a measurement) some joint property of three qubits (projecting the state onto a tripartite-entangled state), the less accurate some other property, local to the three qubits, becomes. We investigate the relation between these complementarity relations and a similar relation based on interference visibilities. We also show that the complementarity relations are particularly tight for particles defined on prime dimensional Hilbert spaces.

Contents

1. Introduction	2
2. Preliminaries	2
3. Complementarity between local and nonlocal qubit observables	4
4. Complementarity through visibility inequalities	4
5. Beyond two-qubit complementarity	8
6. Particles with nonprime dimension	8
7. Conclusions	9
Acknowledgments	9
References	9

1. Introduction

Uncertainty and complementarity are two intriguing and fascinating concepts inherent to quantum theory. Both phenomena can be traced to the linearity of the Schrödinger equation. Undoubtedly, the most well-known relation originating from these concepts is Heisenberg's uncertainty relation [1]. Traditionally, it is presented for canonical observables, such as position and momentum of a particle. Observables defined in a finite Hilbert space are not canonical [2, 3] and obey a related uncertainty relation, the Schrödinger–Robertson (S-R) uncertainty relation [4]. Unfortunately, the latter leads to a trivial lower bound for the uncertainty product, namely zero for any eigenstate of either of the observables. The nontrivial class of states associated with a S-R uncertainty relation are the intelligent states [5]. These have the property that they fulfil the S-R uncertainty relation with equality. However, recently it was pointed out that these states do not give the smallest uncertainty product for any given uncertainty (variance) of one of the observables [6]. Therefore, it seems like the mathematically well-defined intelligent states have little physical significance.

Other kinds of complementarity relations have also been discussed [7]–[12], some more general, but many focusing on the wave-particle duality of quantum mechanics [13]–[21]. In particular for two-state systems, elegant relations between two complementary observables have been derived [15]–[18] (often stated in terms of which-path predictability or distinguishability and interference visibility). Recently, generalizations of these relations have been made to larger Hilbert spaces [22, 23] (and the corresponding relations have then usually been discussed in terms of distinguishability and multi-path ‘interference-visibility’). Another line of generalizations of complementarity relations has targeted ‘simultaneous’ measurements of multiple observables [24]–[27]. Specifically, Zeilinger has proposed that, in fact, pure states uniquely correspond to measurable discrete (e.g., binary) propositions [28]. Together with Brukner, he has also derived an information invariant, that unfortunately only holds for Hilbert spaces of a prime, or prime to an integer power, dimension [29]. This invariant is based on the measurement outcome of a set of mutually unbiased Hermitian operators, as defined by Ivanović [24] and extended by Wootters and Fields [25].

In the context of complementarity, it has been noticed that there also exists a complementarity relation between observation of single-particle interference and two-particle interference [23, 30] (requiring a minimal Hilbert-space dimension of four). In this paper, we extend this idea, combine it with the aforementioned multiobservable complementarity relations, and show that there exists, in fact, a whole set of complementarity relations between single-particle, two-particle, three-particle, etc interference (observed through a proper observable), both if the observations are taken pairwise, or altogether. Hence, the complementary nature between single- and two-photon interference is just a first step of a ladder of similar relations.

2. Preliminaries

In this paper, we shall consider N identical particles (or subsystems), each defined on a d -dimensional Hilbert space \mathcal{H}_d . The Hilbert space of the composite system (all the particles) is hence of dimension $M = d^N$. In this M -dimensional space we call two observables \mathcal{K} and \mathcal{M} mutually unbiased bases (MUB) [25] if all their respective, complete, orthonormal eigenvectors

fulfil

$$|\langle \mathcal{K}, k | \mathcal{M}, m \rangle|^2 = \frac{1}{M} \quad \forall k, m = 1, \dots, M. \quad (1)$$

We already know that the set of MUB can be at most $M + 1$ [24]. It is also known that if d is prime (or M is a prime), the maximal number of MUB can be found [24, 25]. If the Hilbert-space dimension is the product of at least two different prime numbers, it is still unknown how many MUBs exist in the space, although there are some approaches to try to find the solution to this problem in some special cases, such as $M = 6$ or when M is a nonprime integer squared [31]–[33].

If we make a measurement of observable \mathcal{M} on the system, characterized by the state vector $|\psi\rangle$, we get the projection probabilities

$$P_{\mathcal{M}}(m) \equiv |\langle \mathcal{M}, m | \psi \rangle|^2, \quad m = 1, \dots, M. \quad (2)$$

From these, following [26, 27], we define the degree of certainty $C_{\mathcal{M}}$ with which we can estimate the observable \mathcal{M} from

$$C_{\mathcal{M}}^2 \equiv \sum_{m=1}^M P_{\mathcal{M}}^2(m). \quad (3)$$

From the definition follows that $1 \geq C_{\mathcal{M}}^2 \geq 1/M$, where the two bounds are saturated by the eigenstates of observable \mathcal{M} and, e.g., the mutually unbiased observable \mathcal{K} , respectively. The reason we use certainty, rather than uncertainty, to quantify our ability to infer some observable for a given state preparation is that the corresponding complementarity relations take a simple form. The following three relations were proven in [26, 27]:

(1) For any two mutually unbiased observables \mathcal{K} and \mathcal{M}

$$C_{\mathcal{M}}^2 + C_{\mathcal{K}}^2 \leq 1 + \frac{1}{M}. \quad (4)$$

(2) For any number J of mutually unbiased observables we have

$$C_1^2 + \dots + C_J^2 \leq 1 + \frac{J-1}{\sqrt{M}}. \quad (5)$$

(3) If the Hilbert-space dimension d for each particle is a prime, the sharper inequality

$$C_1^2 + \dots + C_J^2 \leq 1 + \frac{J-1}{M} \quad (6)$$

is valid. In this case, the maximum number of MUB are $M + 1$, so for the full set of MUB the following inequality is valid

$$C_1^2 + \dots + C_{M+1}^2 \leq 2. \quad (7)$$

All the equalities convey the same basic message, the higher degree of certainty one obtains of the outcome of one observable, the larger the uncertainty of the outcome of every other observable becomes. This is both true for any pair of mutually unbiased observables, equation (4), and for any set of such observables, equations (5)–(7). Before ending this section it is worth pointing out that there also exist bounds for the products of certainties of MUB that may be useful [26, 27], but we shall ignore these in the following.

3. Complementarity between local and nonlocal qubit observables

The simplest system to demonstrate the ladder of complementarity relations are on qubits. The case of two qubits has already been investigated [25, 34], but for completeness we briefly recapitulate the results here. Hence, we consider the case where $d = 2$, $N = 2$ and $M = 4$. In this case one can find five mutually unbiased observables. As shown in [34], the observables come in two categories. Three of the observables have separable eigenvectors. That is, they each represent two local measurements, each with two possible outcomes. Examples of such mutually unbiased observables are the observables defined by the projectors $\{\hat{\sigma}_{x1} \otimes \hat{1}_2, \hat{1}_1 \otimes \hat{\sigma}_{x2}\}$, $\{\hat{\sigma}_{y1} \otimes \hat{1}_2, \hat{1}_1 \otimes \hat{\sigma}_{y2}\}$ and $\{\hat{\sigma}_{z1} \otimes \hat{1}_2, \hat{1}_1 \otimes \hat{\sigma}_{z2}\}$, where $\hat{\sigma}_{xi}$, $\hat{\sigma}_{yi}$ and $\hat{\sigma}_{zi}$ are the Pauli spin 1/2 observables associated with the i th qubit ($i = 1, 2$). The remaining two observables have nonseparable eigenvectors and are measured in different Bell-state analysers. If we consider the eigenstates of $\hat{\sigma}_{zi}$, both the $\hat{\sigma}_{xi}$ and the $\hat{\sigma}_{yi}$ observable are measurements of equally weighted superpositions of the two eigenstates of $\hat{\sigma}_{zi}$. If we interpret the $\hat{\sigma}_{z1}$ as measuring some ‘particle’ characteristics, then $\hat{\sigma}_{xi}$ and $\hat{\sigma}_{yi}$ can be interpreted as measuring ‘wave’ characteristics [18, 20]. Hence, equation (4) manifests a complementary relation between the two qubits’ local (single particle) wave interferences (probed, e.g., by $\hat{\sigma}_{x1} \otimes \hat{1}_2$ and $\hat{1}_1 \otimes \hat{\sigma}_{x2}$), and the two-particle interference probed by an appropriate Bell-state analyser (in such a way that the two measurements are mutually unbiased).

4. Complementarity through visibility inequalities

In [30], a visibility inequality was demonstrated for an interferometric setup, depicted in figure 1(a). The box marked S denotes a two-particle (qubit) source, emitting one particle into the two paths pointing left, and the other into the paths pointing right. In general, the particles will be emitted into a superposition of the paths. The single-particle visibility was defined in the standard way as

$$v_i = \frac{[P(U_i)]_{\max} - [P(U_i)]_{\min}}{[P(U_i)]_{\max} + [P(U_i)]_{\min}}, \quad (8)$$

where $P(U_i)$ denotes the detection probability of particle i in the upper i th arm in the figure. A two-particle visibility was defined

$$v_{12} = \frac{[\bar{P}(U_1 U_2)]_{\max} - [\bar{P}(U_1 U_2)]_{\min}}{[\bar{P}(U_1 U_2)]_{\max} + [\bar{P}(U_1 U_2)]_{\min}}, \quad (9)$$

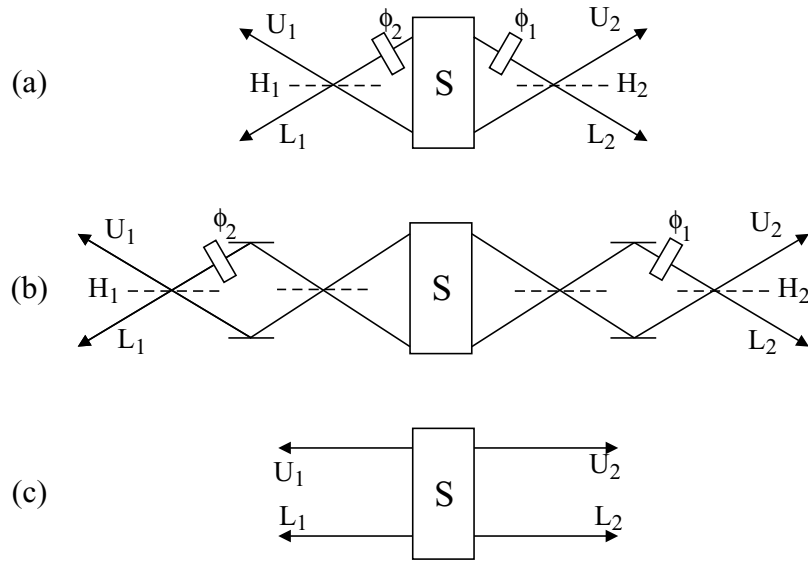

Figure 1. In (a), an interferometric setup for measuring single- and two-particle interference visibility is depicted. H_1 and H_2 denote 50/50 beam splitters. Alternative setups are depicted in (b) and (c).

where

$$\bar{P}(U_1 U_2) \equiv P(U_1 U_2) - P(U_1)P(U_2) + 1/4. \quad (10)$$

This is the joint two-particle detection probability $\bar{P}(U_1 U_2)$ ‘corrected’ for the fact that the two-particle probabilities are, in general, functions of the phases θ and ϕ also for separable states. Jaeger *et al* [30] showed that the two visibilities fulfil the relation

$$v_i^2 + v_{i2}^2 \leq 1, \quad i = 1, 2 \quad (11)$$

for any pure two-particle state. Specifically, the one-parameter class of states

$$|\psi(\alpha)\rangle = \frac{\cos(\alpha)}{\sqrt{2}} (|0, 0\rangle + |1, 1\rangle) + \frac{\sin(\alpha)}{\sqrt{2}} (|0, 1\rangle + |1, 0\rangle) \quad (12)$$

was shown to saturate the invariance relation for every $0 \leq \alpha \leq \pi/4$. If we test the certainty relation (4) for this state, using a local observable that have the state vector $|\psi_i\rangle \equiv |\psi(\pi/4)\rangle = (|0, 0\rangle + |0, 1\rangle + |1, 0\rangle + |1, 1\rangle)/2$ as an eigenstate, and a nonlocal, mutually unbiased observable having maximally entangled eigenstates, we obtain the dotted curve in figure 2. We see that for $\alpha = \pi/4$ (a separable state) we of course have full certainty of the state while for $\alpha = 0$ we are far from the allowed certainty. It is then natural to ask: why? Furthermore, is there any way the relations (4) and (11) agree quantitatively or qualitatively?

The reason (4) and (11) show such a different behaviour for the state $|\psi(0)\rangle$ is evident when we calculate $|\langle\psi(0)|\psi(\pi/4)\rangle| = 1/\sqrt{2}$. We see that $|\psi(\alpha)\rangle$ does not extrapolate between two mutually unbiased two-qubit states (for which the absolute value of the inner product is $1/2$). On the contrary, the states have the *maximal bias* (the maximum overlap) that a separable and a maximally entangled state can have. This also means that the single- and two-particle

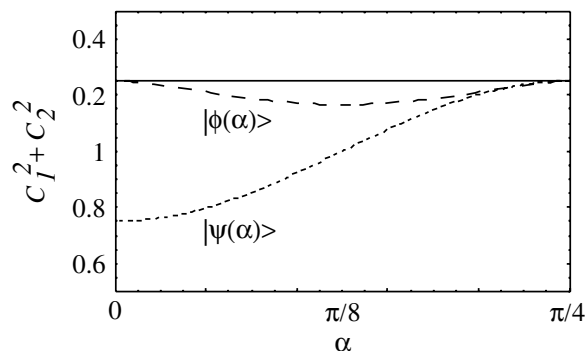

Figure 2. The squared certainty sum. The solid line gives its maximum value.

measurements, quantified by v_i and v_{12} are not mutually unbiased. In fact, both $|\psi(0)\rangle$ and $|\psi(\pi/4)\rangle$ are eigenstates of the operator $\hat{\sigma}_{x1} \otimes \hat{\sigma}_{x2}$. As a consequence, both states have unit ‘uncorrected’ two-particle interference visibility. The correction terms in (10) is necessary for this class of states to saturate the visibility inequality.

A class of states that interpolates between mutually unbiased, separable and maximally entangled states is

$$|\phi(\alpha)\rangle = \frac{\cos(2\alpha)|\phi_n\rangle + \sin(2\alpha)|\psi_l\rangle}{\sqrt{2(2 + \sin(4\alpha))}}, \quad (13)$$

where $|\phi_n\rangle = (|0, 0\rangle + |0, 1\rangle + |1, 0\rangle - |1, 1\rangle)/2$ and $0 \leq \alpha \leq \pi/4$. For this class of states, we see (figure 2, dashed line) that the certainty relation is quite tightly satisfied for the whole class. However, the certainty sum is only saturated at the interval end-points. (One may also note that since the certainty relation (4) is almost saturated for all α , the certainty of each of the remaining three mutually complementary observables must be close to their minimum certainties since the squared certainty sum of the five MUB cannot exceed 2 according to (7).)

A relevant question to ask is how we can measure the respective characteristics of the two mutually unbiased states $|\psi_l\rangle$ and $|\phi_n\rangle$ in some interferometric setup? Because the states are mutually unbiased, the setups must be physically different. We recall that the single-particle interference of the state $|\psi_l\rangle$ is properly characterized by the setup in figure 1 (a). The corresponding single-particle visibilities of state $|\phi_n\rangle$ are zero, and hence the two-particle interference visibility is zero, too. To measure two-particle interference of the state $|\phi_n\rangle$, the set up depicted in figure 1(b) can be used. This setup gives no single- nor two-particle interference for the state $|\psi_l\rangle$ if it is properly adjusted, while the (uncorrected) two-particle interference of the state $|\phi_n\rangle$ is unity. Note, however, that the best we can do is to go from a setting of the phase shifters where $P(U_1U_2) = P(L_1L_2) = 1/2$ to one where $P(U_1L_2) = P(L_1U_2) = 1/2$. It is not possible to make any of the four joint probabilities unity. This requires projection onto a nonseparable operator, a Bell operator, since $|\phi_n\rangle$ is maximally entangled. All setups illustrated in figure 1, on the contrary, represent separable projection operators.

If we use the family of states $|\phi(\alpha)\rangle$ and compute $v_1^2 + v_{12}^2$ we see, in figure 3, that the qualitative behaviour of the squared certainty sum is reproduced. The squared visibility sum is close to its maximum value for all members of the family, but the inequality is only saturated at the end-points.

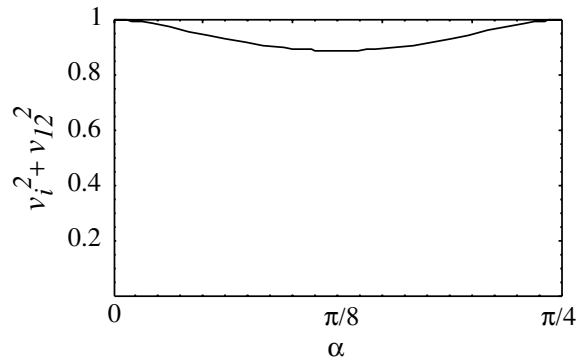

Figure 3. The squared visibility sum.

We note that for every setup consisting of single-particle interferometers, such as those in figure 1, there always exist separable states giving unit visibilities. For the setup depicted in figure 1(b), $|11\rangle$ is such a state. Such states will make $P(U_1)$, $P(U_2)$, and consequently $P(U_1U_2)$ vary between zero and one as a function of the phase settings. In fact, each such setup gives zero multi-particle interference only for a small subclass of separable states. Hence the need to ‘correct’ for such effects when deriving complementarity invariants based on visibilities.

From our examples above, we can conclude that the visibility inequality and the certainty inequality are inequivalent, but qualitatively similar in some cases. In particular, the specific visibility inequality derived in [17] does not probe complementary characteristics in the sense of MUB. A crucial ingredient in the visibility inequality is the subtraction from the single-particle detection probabilities to the two-particle detection probabilities. This subtraction has the purpose to capture the ‘true’ two-particle interference, in essence the entanglement, between the particles. That any setup such as that illustrated in figure 1(a) only captures the entanglement of a small class of states was illustrated by the fact that it gives $v_i = v_{12} = 0$ for the maximally entangled state $|\phi_n\rangle$.

One can ask if some simple form of a similar visibility inequality can be derived for more than two particles. (We are aware of none.) Our tentative answer is no. The main reason is that in analogy with the two-particle case, the three-particle visibility should capture only the three-party entanglement. Hence, one would have to subtract both the single-particle contribution, and the two-particle contribution(s). However, as no universally accepted measure of three-party entanglement exists, it is difficult to see how such a subtraction should be formulated in practice. It is known that with the two setups shown in figures 1(a) and (b) or figures 1(a) and (c), it is possible to fully characterize any two-particle state (pure or mixed). As the two setups provide the projection probabilities of the four projector operators $\hat{\sigma}_{xi}$, $\hat{\sigma}_{yi}$, $\hat{\sigma}_{zi}$, $\hat{1}_i$ for each qubit, the density matrix of any ensemble of identical states can be reconstructed [35]. This is true even for N qubits if two similar setups, each with N interferometric arms, are used. The measured quantities, e.g., the measurement probabilities of $\hat{\sigma}_{x1} \otimes \hat{1}_2$ and $\hat{\sigma}_{z1} \otimes \hat{\sigma}_{z2}$ for two qubits, represent linearly independent, but not mutually unbiased, characteristics [35]. This is the crux of the visibility problem because it means that the measured probabilities simultaneously depend on single- and multi-particle characteristics, as the example with $|\psi(\alpha)\rangle$ aptly demonstrates.

5. Beyond two-qubit complementarity

After the digression in the previous section, let us go back to the certainty relations and consider the case of three qubits. In this case, there are three categories of observables; fully separable, biseparable, and nonseparable. Within these three categories, five different factorization classes exist. If one labels the qubits 1, 2 and 3, we can express the three biseparable partitions 1(23), (12)3 and (13)2. In the three-qubit space there exists four different MUB structures (with respect to generic entanglement classes such as Bell and GHZ entanglements) [36]. One possibility is to have two fully separable, three biseparable and four nonseparable observables. This structure contains observables representing each separability category. In fact, it contains at least one observable corresponding to each of the five factorization classes. The corresponding single-, two- and three-particle interferences consequently are tightly restricted.

If we consider four qubits the complexity increases somewhat. The different MUB structures and factorization classes can be found in [36]. The two-qutrit case has been treated in some detail in [37]. This case is similar to the two-qubit case.

Two observables belonging to different factorization classes quite obviously cannot commute, irrespective if they are mutually unbiased or not. Therefore, probing different kinds of nonlocal properties, through MUBs, visibilities, or otherwise, is bound to be limited by complementarity to some extent. The MUB sets of observables are the ones that take the complementarity to the limit, manifested by equation (7). In this sense the observables correspond to the optimal, discrete, state-defining propositions, where most of them probe nonlocal properties, as suggested by Zeilinger [28].

6. Particles with nonprime dimension

So far, we have looked at subsystems (or particles) defined on a Hilbert space of prime dimension, where particularly restrictive certainty relations exist. What happens if d is composite? The answer is that, in fact, little changes. For the sake of concreteness, let us look at the case of three subsystems, each defined on a six-dimensional Hilbert space. The composite system space dimension can be written $M = 6^3 = (2 \times 3)^3 = 2^3 \times 3^3$. Again, three separability categories and five factorization classes exist. We can now take the one of the two MUB structures (defined by nine observables) containing all factorization classes for three qubits, and tensor multiply it by a selection of nine of the 28 MUB observables that represent similar factorization classes for three qutrits. In this way, we obtain nine MUB observables defined on the 216-dimensional composite space, and this set will cover all the five different factorization classes of the three particles. We see that subsystems defined on a composite-dimensional space will inherit most of the desirable (and also the possibly undesirable) properties from the most restrictive subspace d can be factored into. The main difference between prime- and nonprime-dimensional particles is that we can no longer use the more restrictive certainty relation (7), but are left with the less restrictive inequality (5). A relevant question that will not be addressed in this paper is if this limit can be saturated, and if not, if the inequality can be sharpened.

7. Conclusions

We have demonstrated that for any number of particles, each defined on a Hilbert space of arbitrary dimension, a whole set of complementarity relations between local and nonlocal properties exist. Between any factorization of the particles, corresponding to joint measurements of certain groups of particles and individual measurements of other particles, one can find pairs and whole sets of observables that obey rather tight complementarity relations. It is, of course, possible to find other pairs, or sets, of observables corresponding to any particular factorization of Hilbert space that are not as strongly confined by a certainty or uncertainty relation as the MUB observables are.

We have used certainty as the information measure of each observable, as these complementarity relations take on a simple and aesthetically pleasing form. Other forms of complementarity relations between the same, or similar, observables can probably also be derived. However, as discussed in section 4, generalization of interference measures such as the visibility may prove to be difficult beyond two-particle interference.

Acknowledgments

This work was supported by the Swedish Institute (SI), the Swedish Foundation for International Cooperation in Research and Higher Education (STINT), the Swedish Foundation for Strategic Research (SSF), and the Swedish Research Council (VR). We thank an anonymous reviewer for constructive criticism.

References

- [1] Heisenberg W 1927 *Z. Phys.* **43** 172
- [2] Wintner A 1947 *Phys. Rev.* **71** 738
- [3] Wielandt H 1949 *Math. Ann.* **121** 21
- [4] Schrödinger E 1930 *Proc. Prussian Acad. Sci. Phys. Math. Sec.* **XIX** 296
Schrödinger E 1999 *Preprint quant-ph/9903100* (Engl. Transl.)
Robertson H P 1934 *Phys. Rev.* **35** 667(A)
Robertson H P 1934 *Phys. Rev.* **46** 794
- [5] Aragone C, Guerri G, Salamó S and Tani J L 1974 *J. Phys. A: Math. Nucl. Gen.* **7** L149
Kolodziejczyk I 1975 *J. Phys. A: Math. Gen.* **8** L99
Trifonov D A 1994 *J. Math. Phys.* **35** 5
Puri R R 1994 *Phys. Rev. A* **49** 3
- [6] Pegg D T, Barnett S M, Zambrini R, Franke-Arnold S and Padgett M 2005 *New J. Phys.* **7** 62
- [7] Bialynicki-Birula I and Mycielski J 1975 *Commun. Math. Phys.* **44** 129
- [8] Deutsch D 1983 *Phys. Rev. Lett.* **50** 631
- [9] Uffink J B M and Hilgevoord J 1984 *Phys. Lett. A* **105A** 176
- [10] Krauss K 1987 *Phys. Rev. D* **35** 3070
- [11] Maassen H and Uffink J B M 1988 *Phys. Rev. Lett.* **60** 1103
- [12] Bialynicki-Birula I, Freyberger M and Schleich W 1993 *Phys. Scr. T* **48** 113
- [13] Wootters W K and Zurek W H 1979 *Phys. Rev. D* **19** 473
- [14] Bartell L S 1980 *Phys. Rev. D* **21** 1698
- [15] Greenberger D and Yasin A 1988 *Phys. Lett. A* **128** 391
- [16] Mandel L 1991 *Opt. Lett.* **16** 1882

- [17] Jaeger G, Shimony A and Vaidman L 1995 *Phys. Rev. A* **51** 54
- [18] Englert B-G 1996 *Phys. Rev. Lett.* **77** 2154
- [19] Björk G and Karlsson A 1998 *Phys. Rev. A* **58** 3477
- [20] Björk G, Söderholm J, Trifonov A, Tsegaye T and Karlsson A 1999 *Phys. Rev. A* **60** 1874
- [21] Englert B-G and Bergou J A 2000 *Opt. Commun.* **179** 337
- [22] Dürr S 2001 *Phys. Rev. A* **64** 042113
- [23] Kaszlikowski D, Kwek L C, Zukowski M and Englert B-G 2003 *Phys. Rev. Lett.* **91** 037901
- [24] Ivanović I D 1981 *J. Phys. A: Math. Gen.* **14** 3241
- [25] Wootters W K and Fields B D 1989 *Ann. Phys. (N.Y.)* **191** 363
- [26] Larsen U 1990 *J. Phys. A: Math. Gen.* **23** 1041
- [27] Luis A 2003 *Phys. Rev. A* **67** 032108
- [28] Zeilinger A 1999 *Found. Phys.* **29** 631
- [29] Brukner Č and Zeilinger A 1999 *Phys. Rev. Lett.* **83** 54
Brukner Č and Zeilinger A 2001 *Phys. Rev. A* **63** 022113
- [30] Jaeger G, Horne M A and Shimony A 1993 *Phys. Rev. A* **48** 1023
- [31] Grassl M 2004 *Preprint* [quant-ph/0406175](http://arxiv.org/abs/quant-ph/0406175)
- [32] Wocjan P and Beth T 2005 *Quant. Inf. Comp.* **5** 93
- [33] Archer C 2005 *J. Math. Phys.* **46** 22106
- [34] Lawrence J, Brukner Č and Zeilinger A 2002 *Phys. Rev. A* **65** 032320
- [35] Wootters W K 1990 *Complexity, Entropy and the Physics of Information* ed W Zurek (Reading, MA: Addison-Wesley) p 39
- [36] Romero J L, Björk G, Klimov A B and Sánchez-Soto L L 2005 *Preprint* [quant-ph/0508129](http://arxiv.org/abs/quant-ph/0508129)
- [37] Lawrence J 2004 *Phys. Rev. A* **70** 012302