

## Results in Kalb-Ramond field localization and resonances on deformed branes

This article has been downloaded from IOPscience. Please scroll down to see the full text article.

2009 EPL 88 41001

(<http://iopscience.iop.org/0295-5075/88/4/41001>)

View [the table of contents for this issue](#), or go to the [journal homepage](#) for more

Download details:

IP Address: 38.107.179.214

The article was downloaded on 16/02/2012 at 04:39

Please note that [terms and conditions apply](#).

# Results in Kalb-Ramond field localization and resonances on deformed branes

W. T. CRUZ<sup>1,3</sup>, M. O. TAHIM<sup>2</sup> and C. A. S. ALMEIDA<sup>3(a)</sup>

<sup>1</sup> *Instituto Federal de Educação, Ciência e Tecnologia do Ceará (IFCE), Campus Juazeiro do Norte 63040-000 Juazeiro do Norte, Ceará, Brazil*

<sup>2</sup> *Departamento de Ciências da Natureza, Faculdade de Ciências, Educação e Letras do Sertão Central (FECLESC), Universidade Estadual do Ceará - 63900-000 Quixadá, Ceará, Brazil*

<sup>3</sup> *Departamento de Física, Universidade Federal do Ceará - C.P. 6030, 60455-760 Fortaleza, Ceará, Brazil*

received 3 October 2009; accepted in final form 5 November 2009

published online 4 December 2009

PACS 11.10.Kk – Field theories in dimensions other than four

PACS 11.27.+d – Extended classical solutions; cosmic strings, domain walls, texture

PACS 04.50.-h – Higher-dimensional gravity and other theories of gravity

**Abstract** – We make an analysis about several aspects of localization of the Kalb-Ramond gauge field in a specific four-dimensional AdS membrane embedded in a five-dimensional space-time. The membrane is generated from a deformation of the  $\lambda\phi^4$  potential and belongs to a new class of defect solutions. In this context we find resonance structures in the analysis of massive modes. The study of deformed defects is important because they contain internal structures and these may have implications to the way the background space-time is constructed and the way its curvature behaves. The main objective here is to observe the contributions of the deformation procedure to the resonances and the well-known field localization methods.



Copyright © EPLA, 2009

**Introduction.** – In a scenario of extra dimensions the observable universe is represented by a four-dimensional membrane embedded in a higher-dimensional space-time. The standard model of particles is confined in the membrane while gravitation is free to propagate into the extra dimension. These ideas have appeared as alternatives to solve the gauge hierarchy problem [1]. Recently a lot of attention has been given to the study of topological defects in the context of warped space-times. The number of extra dimensions guides us in choosing the right type of defect in order to mimic our brane world. The key idea for construction of the brane world is to localize in a very natural way the several fields of our universe (the bosonic ones and fermionic ones). In this way several works have considered five-dimensional universes [2,3] where five-dimensional gravity is coupled to scalar fields. In this scenario, with a specific choice for the scalar potential, it is obtained thick domain wall as solutions that may be interpreted as non-singular versions of the Randall-Sundrum scenario. Besides gravity, the study of localization of fields with several spins is very important [4]. Also, this type of scenario contributes

for discussions about cosmology. In models with 5-dimensional membranes, the mechanism controlling the expansion of the universe have been associated to the thickness of the membrane along the extra dimension [5].

As known, the kind of structure of the considered membrane is very important and will produce implications concerning the methods of field localization. In the seminal works of Bazeia and collaborators [6,7] a class of topological defect solutions was constructed starting from a specific deformation of the  $\phi^4$  potential. These new solutions may be used to mimic new brane worlds containing internal structures [7]. Such internal structures have implications in the density of matter energy along the extra dimensions [8] and this produces a space-time background whose curvature has a splitting, as we will show, if compared to the usual models. Some characteristics of such model were considered in phase transitions in warped geometries [9].

Motivated by the references above, our main subject here is to answer the following question: are these structures able to localize the tensor gauge field? In a previous work [10], we find resonances by analyzing the massive spectrum of the Kalb-Ramond field on Bloch branes. Now we analyze the behavior of these structures in a

<sup>(a)</sup>E-mail: carlos@fisica.ufc.br

more complex type of membrane. This letter is organized as follows: in the second section we describe how the deformed membrane is constructed and how the space-time background is obtained; in the third section we study the localization of the Kalb-Ramond gauge field in the background obtained; the fourth section is important because we introduce the dilaton field in order to force the localization of the Kalb-Ramond field. Such analysis is made in the fifth section; in the sixth section we analyze the massive modes using a supersymmetric quantum mechanics formalism; the seventh section deals the resonance structures in the massive spectrum and its relation with deformations. At the final we present our conclusions and perspectives.

**Two-kink solutions modeling the brane.** – There is great interest in studying scalar fields coupled to gravity. If we consider a  $D=5$  universe, we should embed a kink solution in this space-time in order to build our membrane. These kind of solutions are obtained through the  $\lambda\phi^4$  or sine-Gordon potentials. In our case, following the reference [6], we will obtain a new class of defects starting from a deformation of the  $\lambda\phi^4$  potential. In this way we can analyze localization of fields of several ranks in a more complete fashion because the deformed membranes suggests the existence of internal structures. As we will see, this choice avoids space-time singularities also, which is only possible by choosing smooth membrane solutions.

Our model is built with an AdS  $D=5$  space-time whose metric is given by

$$ds^2 = e^{2A(y)} \eta_{\mu\nu} dx^\mu dx^\nu + dy^2. \quad (1)$$

The warp factor is composed by the function  $A(y)$ , where  $y$  is the extra dimension. The tensor  $\eta_{\mu\nu}$  stands for the Minkowski space-time metric and the indexes  $\mu$  and  $\nu$  go from 0 to 3.

In order to construct the membrane solution we start with an action describing the coupling between a real scalar field and gravitation:

$$S = \int d^5x \sqrt{-G} \left[ 2M^3 R - \frac{1}{2} (\partial\phi)^2 - V(\phi) \right]. \quad (2)$$

In the last action, the field  $\phi$  represents the stuff from which the membrane is made,  $M$  is the Planck constant in  $D=5$  and  $R$  is the scalar curvature. The equations of motion coming from that action are

$$\frac{1}{2} (\phi')^2 - V(\phi) = 24M^3 (A')^2, \quad (3)$$

$$\frac{1}{2} (\phi')^2 + V(\phi) = -12M^3 A'' - 24M^3 (A')^2. \quad (4)$$

Note that the prime means derivative with respect to the extra dimension. Basically, we look for solutions in which  $\phi$  tends to different values when  $y \rightarrow \pm\infty$ . In a flat space-time we find kink-like solutions for the above equations

by choosing a double-well potential. Analogously, if we look for bounce-like solutions in curved space-time, we should regard potentials containing various minima. In the presence of gravity, we can find first-order equations by the superpotential method if we take the superpotential  $W(\phi)$  in such a way that  $\frac{\partial W}{\partial \phi} = \phi'$ . Our potential must be defined by

$$V_p(\phi) = \frac{1}{2} \left( \frac{dW}{d\phi} \right)^2 - \frac{8M^3}{3} W^2, \quad (5)$$

from where we can conclude that  $W = -3A'(y)$ . This formalism was initially introduced to study non-supersymmetric domain walls in various dimensions [3,11].

Following refs. [6,7,12,13] the superpotential is given by

$$W_p(\phi) = \frac{p}{2p-1} \phi^{\frac{2p-1}{p}} - \frac{p}{2p+1} \phi^{\frac{2p+1}{p}}, \quad (6)$$

where  $p$  is an odd integer. The choice for  $W_p$  can be obtained by deforming the usual  $\phi^4$  model and it is introduced in the study of deformed membranes [12]. This choice will permit us to get new and well-behaved models for  $p=1, 3, 5, \dots$  (for  $p=1$  we get the usual  $\phi^4$  model). For  $p=3, 5, 7, \dots$ , the potential  $V_p$  has one minimum at  $\phi=0$  and two at  $\pm 1$ . A new class of solutions called two-kink solutions initially presented in ref. [7] can be obtained from the choice of the superpotential  $W_p$ . For this we solve  $\frac{\partial W}{\partial \phi} = \phi'$  to find

$$\phi_p(y) = \tanh^p \left( \frac{y}{p} \right). \quad (7)$$

Starting from the first-order equation  $W_p = -3A'_p(y)$ , we can find the solution for the function  $A_p(y)$  [12],

$$A_p(y) = -\frac{1}{6} \frac{p}{2p+1} \tanh^{2p} \left( \frac{y}{p} \right) - \frac{1}{3} \left( \frac{p^2}{2p-1} - \frac{p^2}{2p+1} \right) \times \left\{ \ln \left[ \cosh \left( \frac{y}{p} \right) \right] - \sum_{n=1}^{p-1} \frac{1}{2n} \tanh^{2n} \left( \frac{y}{p} \right) \right\}. \quad (8)$$

The function  $A(y)$  determines the behavior of the warp factor. The characteristics of localization for several fields and the construction of effective actions in  $D=4$  will depend on part of the contribution of the warp factor. Note that the exponential factor constructed with this function is localized around the membrane and for large  $y$  it approximates the Randall-Sundrum solution [1]. The solution found here reproduces the Randall-Sundrum model in an specific limit. The space-time now has no singularity because we get a smooth warp factor (because of this, the model is more realistic) [4]. In fact this can be seen by calculating the curvature invariants for this geometry. For example, we obtain

$$R = -[8A''_p + 20(A'_p)^2], \quad (9)$$

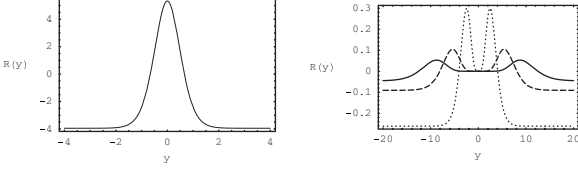

Fig. 1: Plots of the solution of the curvature invariant  $R(y)$   $p=1$  (left) and for  $p=3$  (dashed line),  $p=5$  (dotted line) and  $p=7$  (solid line) (right).

Note that the Ricci scalar is finite, which we can observe through fig. 1. We can see also an important characteristic of the deformed structure in comparison with the usual thick membrane models generated by simple kinks. Observing again fig. 1, for  $p=1$ , we have the usual curvature scalar for the non-deformed model, the usual one. In this case, the curvature has maximum at  $y=0$  and goes to negative values when  $y \rightarrow \infty$ . However, regarding the deformed model, taking  $p=3, 5$  in  $R_p(y)$ , we obtain a splitting with the appearance of a region of zero curvature between two maxima.

**The Kalb-Ramond field.** – In this section we analyze the behavior of the Kalb-Ramond field in the presence of membranes with internal structures. In this case we study mechanisms of localization and normalization for its zero modes and for their Kaluza-Klein modes.

Firstly, we introduce in the action of the deformed membrane the Kalb-Ramond field in the following way:

$$\int d^5x \sqrt{-G} \left[ 2M^3 R - \frac{1}{2} (\partial\phi_p)^2 - V_p(\phi) - H_{MNL} H^{MNL} \right], \quad (10)$$

where  $H_{MNL} = \partial_{[M} B_{NL]}$  is the field strength for the Kalb-Ramond field. We will make the gauge choice  $B_{\alpha 5} = 0$  in such that its non-null components are only those living in the membrane. We have found the equations of motion for  $B_{MN}$  and made explicit the part dependent on the extra dimension:

$$e^{-2A_p} \partial_\mu H^{\mu\gamma\theta} - \partial_y H^{y\gamma\theta} = 0. \quad (11)$$

We make now a separation of variables in order to work the part of the extra dimension,

$$B^{\mu\nu}(x^\alpha, y) = b^{\mu\nu}(x^\alpha) U(y) = b^{\mu\nu}(0) e^{ip_\alpha x^\alpha} U(y), \quad (12)$$

where  $p^2 = -m^2$ . We write  $H^{MNL}$  as  $h^{\mu\nu\lambda} U(y)$ . The equation of motion becomes:

$$\partial_\mu h^{\mu\nu\lambda} U(y) - e^{2A_p} \frac{d^2 U(y)}{dy^2} b^{\nu\lambda} e^{ip_\alpha x^\alpha} = 0. \quad (13)$$

The function  $U(y)$  carry all information about the extra dimension and obeys the following equation:

$$\frac{d^2 U(y)}{dy^2} = -m^2 e^{-2A_p(y)} U(y). \quad (14)$$

When  $m^2=0$  we have the solutions  $U(y) = cy + d$  and  $U(y) = c$  with  $c$  and  $d$  constants. With these at hand we start to make computations in order to find localized zero modes of the Kalb-Ramond field in the deformed membrane. We take the effective action for the tensor field where we decomposed the part dependent on the extra dimension,

$$S \sim \int dy U(y)^2 e^{-2A_p(y)} \int d^4x (h_{\mu\nu\lambda} h^{\mu\nu\lambda}). \quad (15)$$

Given the solutions for  $A_p$  and for  $U(y)$  obtained above, we clearly observe that due to the minus sign in the warp factor, the function  $U(y)^2 e^{-2A_p(y)}$  goes to infinity for the two solutions of  $U(y)$ . In this way, the effective action for the zero mode of the Kalb-Ramond field is not finite after integrating the extra dimension.

**Dilatonic deformed brane.** – In the last section, we have not found signals of existence of zero modes or massive modes trapped to the deformed membrane. The coupling between the membrane (described by a two-bounce solution) and the tensor gauge field is strictly due to the space-time metric. Then, if we want to find localized modes we must modify the structure of our membrane.

In this point, we would like following the procedure of refs. [4,14], where the gauge field localization is produced by including a new scalar field in the model: the dilaton. By adding this field in the Einstein equations, we obtain a new metric behavior and new information about the dynamics of the membrane. The question here is to understand the behavior of the Kalb-Ramond field in this new background.

The first step in this analysis is to study the Einstein equations in this background. We get the action for the membrane, now with two scalar fields [4],

$$S = \int d^5x \sqrt{-G} \left[ 2M^3 R - \frac{1}{2} (\partial\phi)^2 - \frac{1}{2} (\partial\pi)^2 - V_p(\phi, \pi) \right], \quad (16)$$

where we denote by  $\phi$  the scalar field responsible for the membrane. The field  $\pi$  represents the dilaton. It is assumed a new ansatz for the space-time metric:

$$ds^2 = e^{2A(y)} \eta_{\mu\nu} dx^\mu dx^\nu + e^{2B(y)} dy^2. \quad (17)$$

The equations of motion are given by

$$\frac{1}{2} (\phi')^2 + \frac{1}{2} (\pi')^2 - e^{2B(y)} V(\phi, \pi) = 24M^3 (A')^2, \quad (18)$$

$$\frac{1}{2} (\phi')^2 + \frac{1}{2} (\pi')^2 + e^{2B(y)} V(\phi, \pi) = -12M^3 A'' - 24M^3 (A')^2 + 12M^3 A' B', \quad (19)$$

$$\phi'' + (4A' - B')\phi' = \partial_\phi V, \quad (20)$$

$$\pi'' + (4A' - B')\pi' = \partial_\pi V. \quad (21)$$

and

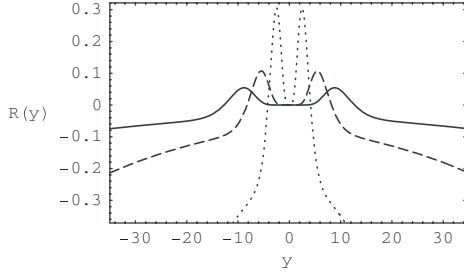

Fig. 2: Plots of the curvature invariant  $R(y)$  with  $p=3, 5, 7$  (dotted, dashed and solid line, respectively).

To obtain the first-order equations, we choose the following superpotential  $W_p(\phi)$  [4]:

$$V_p = e^{\frac{\pi}{\sqrt{12M^3}}} \left\{ \frac{1}{2} \left( \frac{\partial W_p}{\partial \phi} \right)^2 - \frac{5M^2}{2} W_p(\phi)^2 \right\}. \quad (22)$$

The two-kink solutions of the general form (7) are used in eq. (6) and we obtain:

$$\pi = -\sqrt{3M^3} A_p, \quad B = \frac{A_p}{4} = -\frac{\pi}{4\sqrt{3M^3}}, \quad A'_p = -\frac{W_p}{3}. \quad (23)$$

Contrary to the AdS space-time with negative constant curvature provided by the deformed brane scenario, as we can see in eq. (23), the solution for the dilaton makes the space-time singular. The Ricci scalar for this new geometry is now given by

$$R = -[8A_p'' + 18(A_p')^2] e^{\frac{\pi}{2\sqrt{3M^3}}}. \quad (24)$$

From fig. 2, we note that there is a region near the membrane where the Ricci scalar is null. When we take different values for  $p$ , the width of this region increases due to the deformation introduced. Due to the dilaton coupling, the curvature scalar decreases indefinitely in regions far from the membrane. However this kind of singularity is very common in  $D$ -brane solutions where the dilaton solution is divergent [4]. The work [15] presents some comments about how these singularities can be made harmless.

### Kalb-Ramond field on dilatonic deformed brane.

– Now we try again to localize the tensor gauge field, but in the new background described in the section above. The issue here is to verify if the dilaton coupling will be enough to localize the Kalb-Ramond field in the deformed membrane. The dilaton coupling is introduced in the model in the following way [16,17]:

$$S \sim \int d^5x (e^{-\lambda\pi} H_{MNL} H^{MNL}). \quad (25)$$

Therefore, we must analyze the equations of motion of the tensor gauge field in the dilaton background. The new equation of motion is

$$\partial_M (\sqrt{-g} g^{MP} g^{NQ} g^{LR} e^{-\lambda\pi} H_{PQR}) = 0. \quad (26)$$

With the gauge choice  $B_{\alpha 5} = \partial_\mu B^{\mu\nu} = 0$  and with the separation of variables  $B^{\mu\nu}(x^\alpha, y) = b^{\mu\nu}(x^\alpha)U(y) = b^{\mu\nu}(0)e^{ip_\alpha x^\alpha}U(y)$ , where  $p^2 = -m^2$ , a differential equation which gives us information about the extra dimension is obtained, namely

$$\frac{d^2U(y)}{dy^2} - (\lambda\pi'(y) + B'(y)) \frac{dU(y)}{dy} = -m^2 e^{2(B(y)-A(y))} U(y). \quad (27)$$

For the zero mode,  $m=0$ , a particular solution of the equation above is simply  $U(y) \equiv cte$ . This is enough for the following discussion. The effective action for the zero mode in  $D=5$  is

$$S \sim \int d^5x (e^{-\lambda\pi} H_{MNL} H^{MNL}) = \int dy U(y)^2 e^{(-2A(y)+B(y)-\lambda\pi(y))} \int d^4x (h_{\mu\nu\alpha} h^{\mu\nu\alpha}). \quad (28)$$

Given the solution  $U(y)$  constant and regarding the solutions for  $A_p(y)$ ,  $B(y)$  e  $\pi(y)$ , it is possible to show clearly that the integral in the  $y$  variable above is finite if  $\lambda > \frac{7}{4\sqrt{3M^3}}$ , and for  $p$  finite. As a consequence, for a specific value of the coupling constant  $\lambda$  it is possible to obtain a localized zero mode of the Kalb-Ramond field.

**Massive modes.** – We should now consider a discussion about massive modes in this background. For this, we must analyze eq. (27) for  $m \neq 0$  trying to write it in a Schroedinger-like equation through the following change:

$$dz = dy e^{-\frac{3}{4}A_p}, \quad U = e^{(\frac{\alpha}{2} + \frac{3}{8})A\bar{U}}, \quad \alpha = \frac{1}{4} - \sqrt{3M^3}\lambda. \quad (29)$$

After all the necessary calculations we arrive at the equation we want to analyze, namely

$$\left\{ -\frac{d^2}{dz^2} + \bar{V}(z) \right\} \bar{U} = m^2 \bar{U}, \quad (30)$$

where the potential  $\bar{V}_p(z)$  assumes the form,

$$\bar{V}_p(z) = \left[ \beta^2 (\dot{A}_p)^2 - \beta \ddot{A}_p \right], \quad \beta = \frac{\alpha}{2} + \frac{3}{8}. \quad (31)$$

We can see from fig. 3 that the potential is affected by the deformation procedure introduced in this work. We identify the existence of two minima whose distance increases when we increase the values of  $p$ . The form of the potential is also directly changed. Note that we use  $\sqrt{3M^3}\lambda > 1$  in order to obtain a potential like (31), *i.e.*, the standard form found when we write Schrodinger-like equations. This choice is fundamental in order to find finite results regarding the behavior of the Kalb-Ramond field.

It is interesting to point out that the Schrodinger-type equation (30) can be written in the supersymmetric quantum mechanics scenario as follows:

$$Q^\dagger Q \bar{U}(z) = \left\{ \frac{d}{dz} - \beta \dot{A} \right\} \left\{ \frac{d}{dz} + \beta \dot{A} \right\} \bar{U}(z) = -m^2 \bar{U}(z). \quad (32)$$

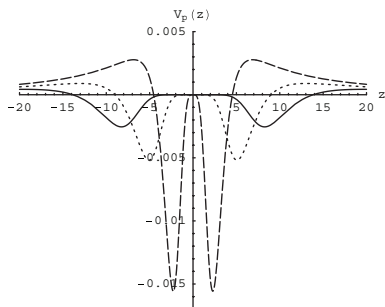

Fig. 3: Plots of the potential  $\bar{V}_p(z)$  with  $p=3$  (dashed line),  $p=5$  (dotted line) and  $p=7$  (solid line). We have put  $\sqrt{3M^3}\lambda=2$ .

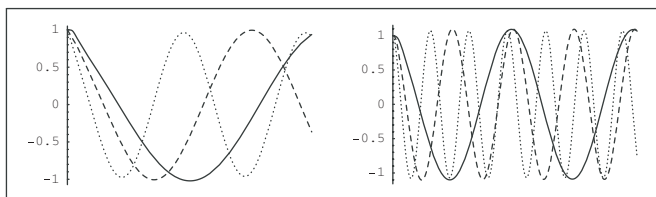

Fig. 4: Plots of  $\bar{U}_p(z)$  for  $p=1$  (dotted line),  $p=3$  (dashed line) and  $p=5$  (solid line), where we put  $m^2 \leq \bar{V}_p(z)_{max}$  (left) and  $m^2 > \bar{V}_p(z)_{max}$  (right). We use  $\sqrt{3M^3}\lambda=2$ .

From the form of eq. (32), we exclude the possibility of normalized negative energy modes to exist. On the other hand, we exclude also the possibility of the presence of tachyonic modes, which is a necessary condition to keep the stability of gravitational background.

We cannot find analytical solution of the massive modes wave function in Schrodinger equation. However, we will be able to analyze the solution for  $\bar{U}_p$  by numerically solving eq. (30). We plot in fig. 4 the wave function so obtained for two values of  $m^2$ . As we can observe, when we make  $m^2 > \bar{V}_p(z)_{max}$ , we minimize the contribution due to the deformations over the solution  $\bar{U}_p$ . However, regarding  $m^2 \leq \bar{V}_p(z)_{max}$ , as we increase  $p$  we reduce the frequency of oscillations of the solutions  $\bar{U}_p$ . We must remember that the search for finite solutions it was only possible due to the choice  $\sqrt{3M^3}\lambda > 1$ .

As mentioned in ref. [12], the behavior of the wave function suggests us a free motion in the bulk, but no trapping in the membrane. An interesting point to be investigated is how the intensity of the dilaton constant coupling may modify the patterns of solutions observed in fig. 4. For this, we solve again eq. (30), but this time, changing the values of the constant coupling  $\lambda$ . We plot in fig. 5 the function  $\bar{U}_p(z)$ , this time for  $\sqrt{3M^3}\lambda=20$  on the left and  $\sqrt{3M^3}\lambda=40$  on the right. We note the suppression of the mode oscillations in regions near the membrane due to the increasing of  $\lambda$ . On the other hand, in regions far away from  $z=0$  the amplitude oscillations grows.

**Resonances.** – The study of the resonances is important since it can gives relevant information about the

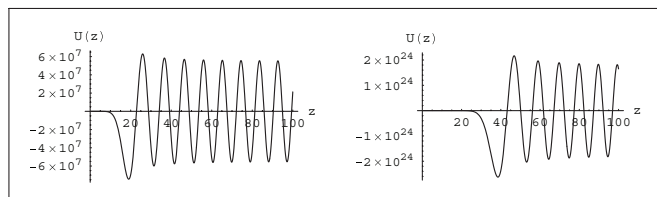

Fig. 5: Plots of  $\bar{U}_p(z)$  for  $p=1$ , where we put  $m=0, 5$ ,  $\sqrt{3M^3}\lambda=20$  (left) and  $\sqrt{3M^3}\lambda=40$  (right).

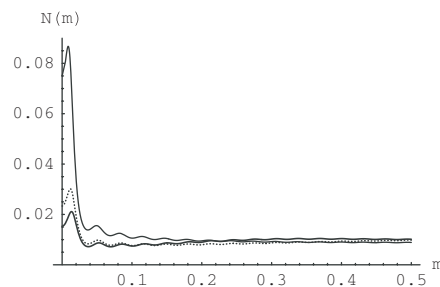

Fig. 6: Plots of  $N_p(m)$  for  $p=1$  (thin line),  $p=3$  (points) and  $p=5$  (thick line). We use  $\sqrt{3M^3}\lambda=2$ .

massive modes [18–23]. In order to better understand the coupling between massive modes and matter on the membrane we should know, starting from eq. (32), the amplitude of the plane wave function  $\bar{U}_p(z)$  normalized at  $z=0$ . As is pointed out in refs. [2] and [24], for highly massive modes in relation to  $\bar{V}(z)_{max}$ , the potential represents only a little perturbation. Nevertheless, it is possible that modes of the function  $\bar{U}(z)$  for which  $m^2 \leq \bar{V}(z)_{max}$  can resonate with the potential. The quantity  $|\zeta \bar{U}_m(0)|^2$ , being  $\zeta$  a normalization constant, should give us the probability of finding a mode of mass  $m$  at  $z=0$  and is given by

$$N_p(m) = \frac{|\bar{U}_m(0)|^2}{\int_{-100}^{100} |\bar{U}_m(z)|^2 dz}. \quad (33)$$

In fig. 6 we plot  $N_p(m) = |\zeta \bar{U}_p(0)|^2$  where we can identify, for  $p=1$ , a resonant peak near  $m=0$ , precisely for  $m=9 \times 10^{-3}$ . We may interpret that, in this case, the probability of finding light modes or massless modes coupled to the membrane is bigger than for heavier modes. This characteristics disappears when we change the values of  $p$ . As we can observe in fig. 6, the resonant structure tends to disappear in accordance to the results of localization of the zero mode.

We can still test the consistency of the above results regarding again the model without the dilaton coupling. In this case, we do not find signals of localization of the Kalb-Ramond field. In this way, supressing the dilaton coupling, we can extract the function  $N_p(m)$  from eq. (30) by the same steps discussed before and plot the results in fig. 7. As we expect, the resonant structure disappears and the couplings of the zero modes is highly suppressed.

**Conclusions.** – In this article we analyze under several aspects the localization properties of the Kalb-Ramond

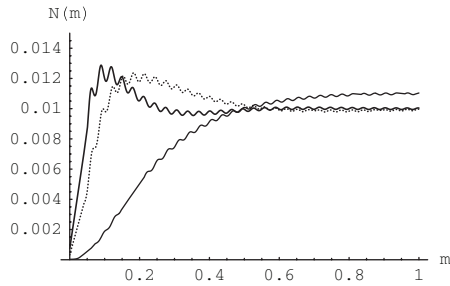

Fig. 7: Plots of  $N_p(m)$  for  $p=1$  (thin line),  $p=3$  (points) and  $p=5$  (thick line). We use  $\sqrt{3M^3}\lambda=0$ .

tensor gauge field in a very specific type of membrane: the deformed membrane.

The analysis of the Kalb-Ramond field is jeopardized since the effective action is not normalizable: we have not zero modes for the Kalb-Ramond field. The resulting equation of motion for the massive modes is not found and it can not be written in a form of Schrodinger-like equation. This fact do not allows us to interpret quantum mechanically the problem. What we do to circumvent this result is to add one more field in the model, the dilaton, and this changes a little the gravitational background. After this modification, we can, under some conditions, find a localized tensorial zero mode. Related to the spectra of massive states, we see that the effective potential in the Schrodinger-like equation is affected by the deformations made in the membranes. The numerical analysis of that equation for massive states reveals that there are plane waves describing the free propagation of particles in the bulk. The dilaton coupling change the amplitude of oscillations of the modes away from the membrane. Indeed, studying the coupling of the matter massive states with the membrane we have found a resonance, which again disappears with the deformations. The resonance structures show us that only light modes of the KK spectrum present not suppressed coupling with the membrane. Finally, we showed the consistency of the results obtained with those from the model without the dilaton.

\*\*\*

The authors would like to thank Fundação Cearense de apoio ao Desenvolvimento Científico e Tecnológico

(FUNCAP) and Conselho Nacional de Desenvolvimento Científico e Tecnológico (CNPq) for financial support.

## REFERENCES

- [1] RANDALL L. and SUNDRUM R., *Phys. Rev. Lett.*, **83** (1999) 3370.
- [2] GREMM M., *Phys. Lett. B*, **478** (2000) 434.
- [3] DEWOLFE O., FREEDMAN D. Z., GUBSER S. S. and KARCH A., *Phys. Rev. D*, **62** (2000) 046008.
- [4] KEHAGIAS A. and TAMVAKIS K., *Phys. Lett. B*, **504** (2001) 38.
- [5] SADEGH MOVAHED M. and GHASSEMI S., *Phys. Rev. D*, **76** (2007) 084037.
- [6] BAZEIA D. and LOSANO L., *Phys. Rev. D*, **73** (2006) 025016.
- [7] BAZEIA D., MENEZES J. and MENEZES R., *Phys. Rev. Lett.*, **91** (2003) 241601.
- [8] BAZEIA D., FURTADO C. and GOMES A. R., *J. Cosmol. Astropart. Phys.*, **02** (2004) 002.
- [9] CAMPOS A., *Phys. Rev. Lett.*, **88** (2002) 141602.
- [10] TAHIM M. O., CRUZ W. T. and ALMEIDA C. A. S., *Phys. Rev. D*, **79** (2009) 085022.
- [11] SKENDERIS K. and TOWNSEND P. K., *Phys. Lett. B*, **468** (1999) 46.
- [12] BAZEIA D. and GOMES A. R., *JHEP*, **05** (2004) 012.
- [13] BAZEIA D., RIBEIRO R. F. and SANTOS M. M., *Phys. Rev. D*, **54** (1996) 1852.
- [14] GHOROKU KAZUO, TACHIBANA MOTOI and UEKUSA NOBUHIRO, *Phys. Rev. D*, **68** (2003) 125002.
- [15] GREMM M., *Phys. Rev. D*, **62** (2000) 044017.
- [16] SFETSOS K. and TSEYTLIN A. A., *Phys. Rev. D*, **49** (1994) 2933.
- [17] KLEIHAUS B., KUNZ J. and MYKLEVOLL K., *Phys. Lett. B*, **605** (2005) 151.
- [18] ALMEIDA C. A. S., FERREIRA M. M. jr., GOMES A. R. and CASANA R., *Phys. Rev. D*, **79** (2009) 125022.
- [19] LIU YU-XIAO, FU CHEN-E, ZHAO LI and DUAN YI-SHI, *Phys. Rev. D*, **80** (2009) 065020.
- [20] LIU YU-XIAO, YANG JIE, ZHAO ZHEN-HUA, FU CHEN-E and DUAN YI-SHI, *Phys. Rev. D*, **80** (2009) 065019.
- [21] BAZEIA D., GOMES A. R. and LOSANO L., *Int. J. Mod. Phys. A*, **24** (2009) 1135.
- [22] CVETIC M. and ROBNIK M., *Phys. Rev. D*, **77** (2008) 124003.
- [23] LIU Y.-X., LI H.-T., ZHAO Z.-H., LI J.-X. and REN J.-R., *JHEP*, **10** (2009) 091.
- [24] CSAKI C., ERLICH J., HOLLOWOOD T. J. and SHIRMAN Y., *Nucl. Phys. B*, **581** (2000) 309.